

## PROFILES

### / Profile overview

#### / Contact-Duo-Profiles

#### / Quadro-Profiles

#### / Rubber-Sheath-Profiles

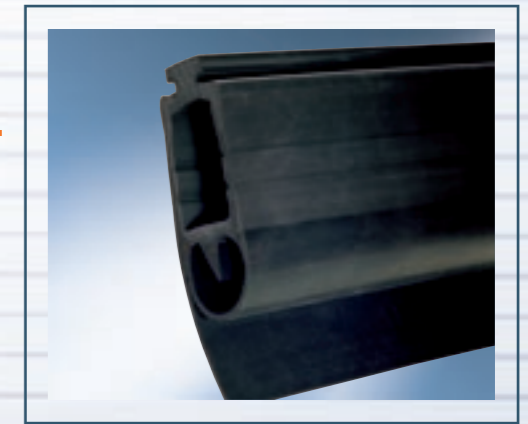
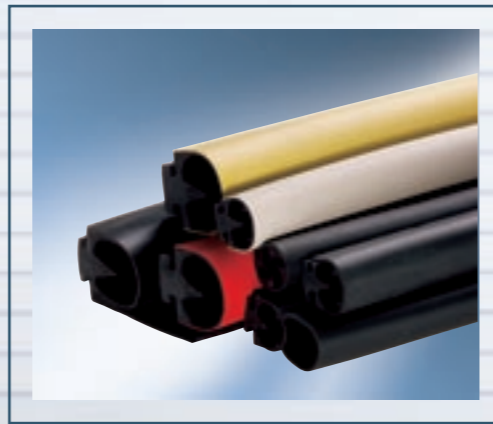

### / Contact-Duo-Profiles – for dependable contacting

The Gelbau Contact-Duo-Profiles are ultra-flexible, one-piece rubber profiles made of EPDM or NBR, ideally matched to the closing edge of the gate or machine involved. The maximum actuating force lies well below the 150 N stipulated in the standard. In conjunction with the accessories offered and plug connection technology, the system can be easily and reliably assembled.



The maximum switching strip length is 100 m. Besides the use of prefabricated corner connectors with specified angles (90°, 120°, 135° and 150°) for the profiles 3100.0110I

and 3100.0110N, all profile types can also be assembled with divergent angular dimensions requested by the customer. The switching strip can thus be optimally adapted to suit the contour of the closing edge concerned, enabling one-piece corner-switching solutions to be created. Plane offset and circular installation for a radius of at least 300 mm are possible.

A broad range of profiles is available for the various applications and requirements involved. All of them feature ultra-flexible, one-piece construction. Profile types with a compensation chamber guarantee the required compensation travel, depending on the overall height involved. The optional sealing lip compensates for any unevenness in the floor, and provides reliable sealing for the door. Two different profile feet (standard and Braselmann foot) ensure firm, secure attachment to standard mounting rails.

The rubber mixtures used, featuring EPDM and NBR, guarantee high functional reliability even under adverse conditions like moisture and dirt, as well as cold and heat. Thanks to their permanently resilient properties, they offer a high degree of protection against mechanical damage. Their good resistance to ageing guarantees these characteristics even over a lengthy period of time. NBR is, moreover, highly resistant to oils and lubricants.

The system components available for Gelbau Contact-Duo-Profiles are, in addition to other optional accessories: evaluator, plug connector with connecting cable, terminating plug connector with resistor, and end cap.

### / Quadro-Profiles – all good things come in fours

The Gelbau Quadro-Profile is used primarily in the field of local public transport, where it is installed as a safety feature for the closing edges of passenger doors in buses and trains. The EPDM profile can be used only in conjunction with a sealing profile. It is simply pushed into the hollow chamber of existing or newly developed sealing profiles. The profiles have a diameter of 18 mm or 22 mm, and require a sheath-profile with a hollow compartment minimum diameter of 21.5 mm or 25.5 mm. The profile is characterised by a high level of sensitivity.



The Gelbau Quadro-Profile has an action range of 360°, and is fully insulated on the outside. When the conductive zones are touched due to mechanical pressure, this results in electrical contacting. At least three out of the four electrically conductive zones will always touch each other when subjected to mechanical pressure, thus ensuring reliable contacting. The evaluation electronics here open the potential-isolated safety contact, which triggers opening of the door. The high contact pressure achieved thanks to a small contact area assures self-cleaning of the contact surface.

The system components available for the Gelbau Quadro-Profile are: evaluator, plug connector with connecting cable, terminating plug connector with resistor, flexible wire jumper, and end cap. Using these components guarantees a switching sensitivity down to the very last millimetre.

### / Rubber-Sheath-Profiles – vertical protection

Doors with vertical closing edges, e. g. folding doors, have a crossbeam width of approx. 50 mm and a gap width requiring to be safeguarded of at least 120 mm. The closing edge safety feature is required to cover the entire crossbeam width and to close and seal the gap without triggering the switching strip. At the same time, it is required to possess high lateral sensitivity, so that a possible pinch is detected as soon as the door wings are turned. The rubber-sheath-profile developed specifically for this application, with the associated aluminium special rail and the Contact-Duo-Profile 3100.1610, meets these requirements.



# CONTACT-DUO-PROFILE

## / Contact-Duo-Profile overview

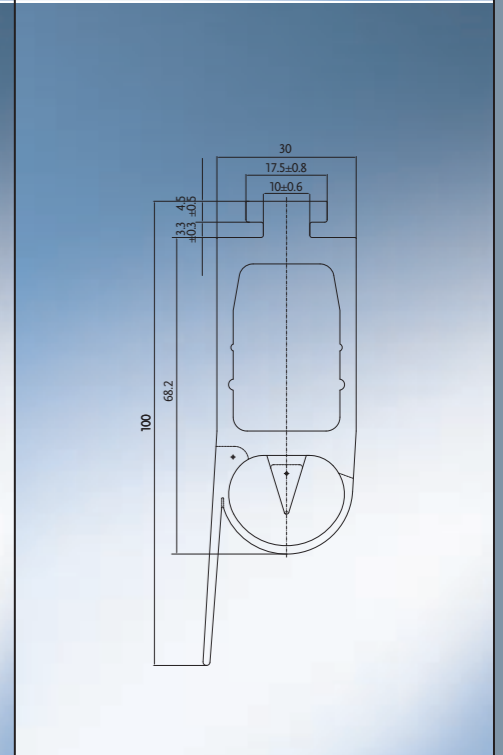
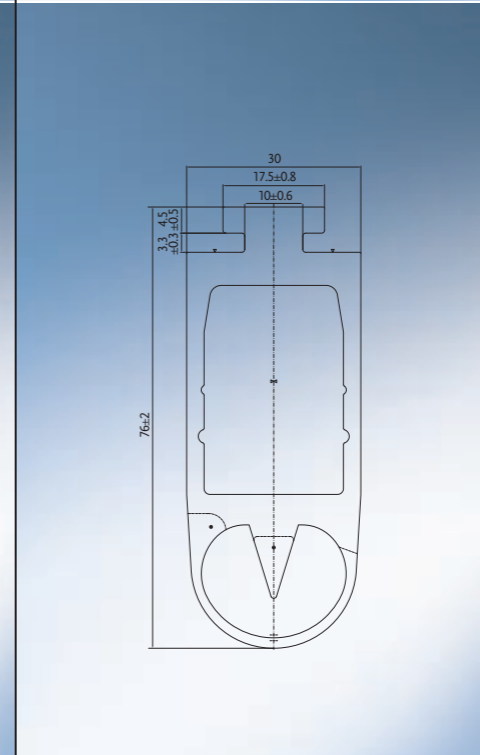
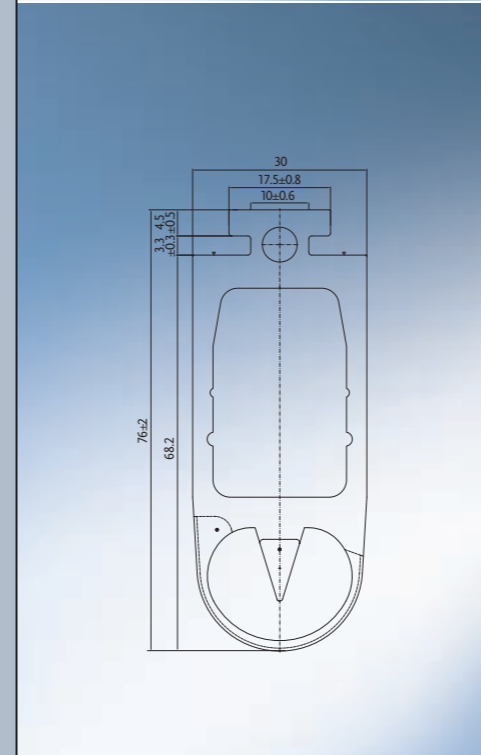
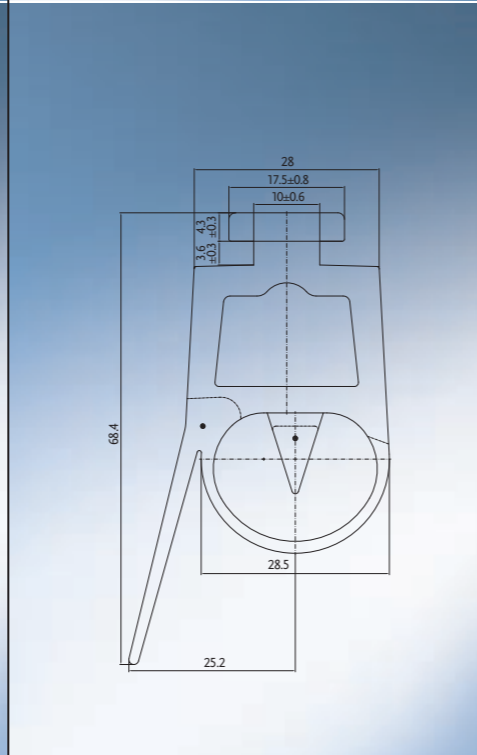
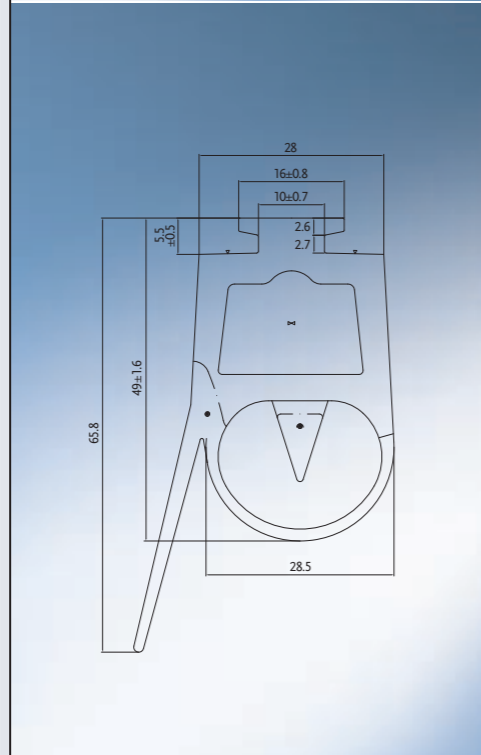
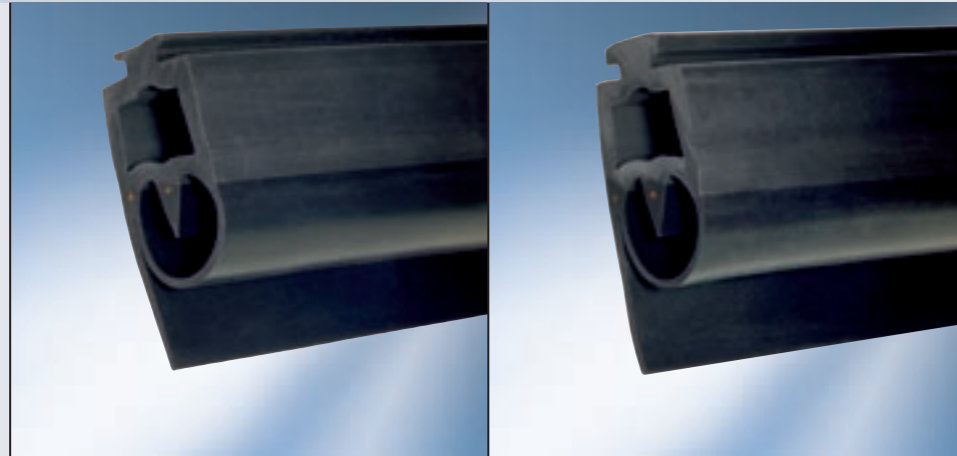
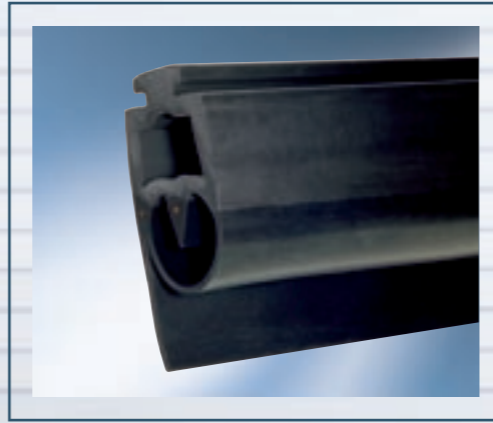

### Profile overview

Type	008.02	008.04
Article no.	3100.0802	3100.0804
Colour	Black	Black
Material	EPDM	EPDM
Profile foot	Braselmann	T-foot
Switching head, insulated	No	No
Sealing lip	Yes	Yes
Connection types	AAS/AOS (standard)	AAS/AOS (standard)
Delivery length	20 m	20 m
Min. diameter, sheath profile		

Type	003.10I	003.10N	002.10
Article no.	3100.0310I	3100.0310N	3100.0210
Colour	Black	Black	Black
Material	EPDM	NBR	EPDM
Profile foot	T-foot	T-foot	T-foot
Switching head, insulated	Yes	No	No
Sealing lip	No	No	Yes
Connection types	AAS/AOS (standard)	AAS/AOS (standard)	AAS/AOS (standard)
Delivery length	20 m	20 m	20 m
Min. diameter, sheath profile			

For dimensions without tolerance particulars, tolerance-free dimensions as per DIN ISO 3302-1 E2 shall apply.









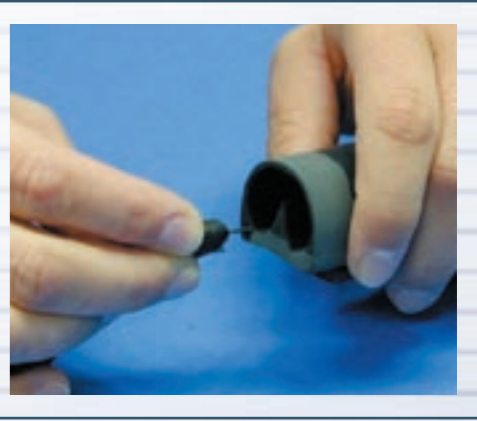







# INSTALLATION INSTRUCTIONS

## / Installation instructions for Contact-Duo-Profiles

as exemplified by a profile without compensation chamber and without sealing lip



Step	Detailed description	Notes
<b>0</b>	<b>Tools required</b> Rubber scissors, knife, electronic side-cutter, sandpaper (grain size 80), belt punch, pointed pliers	
<b>1</b> Cutting the profile to size	<b>Cutting the profile to length</b> 1.1 Total length of the switching strip minus 34 mm for the end caps (17 mm per cap). 	When cutting to size, make sure the cut edges are straight, smooth and right-angled.
<b>2</b> Shortening the foot by the dimension of the end cap's circumferential edge	<b>Right-angled cross-section</b> 2.1 Cut at right angles into the foot after 12 mm. 	Take care to ensure that you do not damage the profile when making the right-angled cut. 
	<b>Axial cross-section</b> 2.2 Cut off the foot after 12 mm up to the right-angled cut. Any protruding remains of the foot will have to be sanded off later.  	
<b>3</b> Shortening the copper wires	<b>Shortening</b> 3.1 Shorten the copper wire with flush precision. 	This step enables you to achieve a smooth sanding surface.
<b>4</b> Sanding the profile	<b>Cut surface</b> 4.1 Sand the cut surface until it is even and matt. 	Important: the edges must not be sanded until they are round. Straight-cut edges guarantee reliable adhesion. During this procedure, take care to ensure that soiling (grinding dust, foreign bodies, adhesive, etc.) does not penetrate into the switching chamber. 
	<b>Profile foot</b> 4.2 The remaining rib of the profile foot must be completely sanded until it is even. 	

Step	Detailed description	Notes
<b>4</b>	<b>Switching head</b> 4.3 Sand the surface of the switching head to the width of the circumferential edge (at least 12 mm) until it is matt. 	
<b>5</b> Preparing the end cap for the connecting cable	<b>Opening the cable bushing</b> 5.1 The cable bushings are closed inside. In accordance with the type of connection involved, open the desired bushing with a belt punch (pipe 4.5). Remove the remaining closure, using pointed pliers if necessary. 	Insert the spike of the belt punch precisely into the cable bushing, taking care not to damage the bushing.
	<b>Pulling through the cable</b> 5.2 Pull the connecting cable in through the perforated cable bushing until shortly before the cap, using pointed pliers if necessary.  	
<b>6</b> Inserting the plug connector with the connecting cable	<b>Prepunching</b> 6.1 Use the needle of the terminating plug connector to prepunch in the centre of the top and bottom copper wires. 	The plug connector must be inserted in the centre of the copper wires, so as to ensure reliable contacting.
	<b>Insertion</b> 6.2 Now plug the plug connector with the connecting cable into the prepunched copper wire. 	The tapering end of the plug connector must face outwards and the round side towards the switching wedge. Only in this configuration will the cap close properly.  In the case of a cable exiting at the side, the corresponding spacer must be removed at the plug connector on the cable outlet side, using a side-cutter. Be careful of parts flying off! Wear eye protection.

# INSTALLATION INSTRUCTIONS

## / Installation instructions for Contact-Duo-Profiles

as exemplified by a profile without compensation chamber and without sealing lip



Step	Detailed description	Notes
<b>7</b> Wetting the interior rib with adhesive	<b>Wetting</b> Apply a thin but even film of adhesive to the rib. Applying too much adhesive will impair the adhesion properties. <b>7.1</b>	Important: when wetting the rib with adhesive, make sure that no adhesive gets onto the inner sealing edge of the end cap and on the cable of the plug connector. The adhesive sets immediately, and then it will no longer be possible to shift the parts.  Use the adhesive with the utmost care. Avoid any contact with skin and eyes, and always comply with the safety instructions on the tube.  Only our adhesive is matched to the components involved.
<b>8</b> Fitting the end cap	<b>Fitting</b> Place the end cap on the profile from the profile foot side. It is particularly important to make sure the corners are positioned correctly, so that the cap does not jam when being pushed on. Then press the cap firmly for about 10 seconds. Only a short time should elapse between applying the adhesive and pressing on the cap. <b>8.1</b>	When fitting the cap, the cable must also be pulled through the bushing, without withdrawing the plug connector from the copper wires. We recommend practising this procedure several times without adhesive. With adhesive, there will no longer be any opportunity to make a correction.  When practising, repeatedly pull the plug connector approx. 50 mm out of the end cap again, then plug the plug connector into the copper wires, and then fit the end cap.
<b>9</b> Gluing the end cap in place	<b>Gluing on the foot side of the profile</b> Fold back the circumferential edge and apply a thin, even film of adhesive to the adhesive surface of the foot. Fold the sealing edge back into position, first press the two corners down so that the end cap cannot shift, and for approximately 10 seconds press onto the entire adhesion surface. <b>9.1</b>  <b>Gluing the switching chamber</b> Fold back the circumferential edge, and apply a thin, even coating of adhesive to the right or left half as far as the centre, all the way into the corners. Fold the circumferential edge back into position and for approx. 10 seconds press the adhesion surface. Then fold back the circumferential edge again... <b>9.2</b>	

Step	Detailed description	Notes
<b>9</b> Gluing the end cap in place	<b>Gluing the end cap in place</b> ... and likewise spread the other half with a thin, even film of adhesive right into the corners. Fold the circumferential back into position, and once more press the adhesion surface for approx. 10 seconds. <b>9.2</b>  <b>Gluing the cable exit</b> Carefully bend away the cable protruding from the bushing and allow the adhesive to run into the bushing around the cable. <b>9.3</b>	
<b>10</b> Sealing	<b>Sealing the end cap</b> Apply a thin film of adhesive to the edge of the end cap. <b>10.1</b>  <b>Sealing the edge at the cable bushing</b> Apply a thin film of adhesive to the edge of the cable bushing. <b>10.2</b>	If the adhesive cracks when the dry profile is pressed together, this is only a sign that there is superfluous adhesive present.
<b>To process the other side of the profile, repeat steps 1 to 4 and then proceed from step 11.</b>		
<b>11</b> Fitting the terminating plug connector (diode/resistor)	<b>Prepunching</b> Use the needle of the terminating plug connector to prepunch the centre of the top and bottom copper wires (see also sections 6.1 and 6.2). <b>11.1</b>  <b>Inserting</b> Now insert the terminating plug connector in the prepunched copper wire. <b>11.2</b>	The plug connector must be inserted in the centre of the copper wires, so as to ensure reliable contacting.  The tapering end of the plug connector must face outwards and the round side towards the switching wedge. Only in this configuration will the cap close properly.
<b>From here, repeat steps 7 to 10.</b>		