

- H9H load cells are available in the capacities 50Klb~100Klb.
- Alloy steel construction, potted by adhesive inside, oil proof, waterproof, anti-corrosive gas and medium making it suitable for all kinds of environments.
- Dual shear beam, suitable for electronic truck scales, hopper scales, track scales and other electronic weighing devices.

Features

- Capacity 50Klb~100Klb
- High accuracy
- Alloy steel construction
- Easy installation and reliable performance

Specifications

Capacity	Klb	50/60/75/100			
Accuracy		C2	C3	A5S	A5M
Maximum number of verification intervals	n _{max}	2000	3000	5000	5000
Minimum load cell verification interval	v _{min}	E _{max} /5000	E _{max} /10000	E _{max} /15000	E _{max} /15000
Combined error	(%FS)	≤ ±0.030	≤ ±0.020	≤ ±0.018	≤ ±0.026
Creep	(%FS/30min)	≤ ±0.024	≤ ±0.016	≤ ±0.012	≤ ±0.017
Temperature effect on sensitivity	(%FS/10°C)	≤ ±0.017	≤ ±0.011	≤ ±0.009	≤ ±0.013
Temperature effect on zero	(%FS/10°C)	≤ ±0.023	≤ ±0.015	≤ ±0.010	≤ ±0.014
Output sensitivity	(mv/v)	3.0±0.003			
Input resistance	(Ω)	700±7			
Output resistance	(Ω)	703±4			
Insulation resistance	(MΩ)	≥5000(50VDC)			
Zero balance	(%FS)	1.0			
Temperature, compensated	(°C)	-10~+40			
Temperature, operating	(°C)	-35~+65			
Excitation, recommended	(V)	5~12(DC)			
Excitation, max	(V)	18(DC)			
Safe overload	(%FS)	150			
Ultimate overload	(%FS)	300			

Outline Dimension mm(inch)

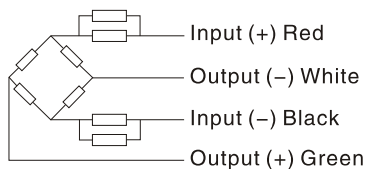
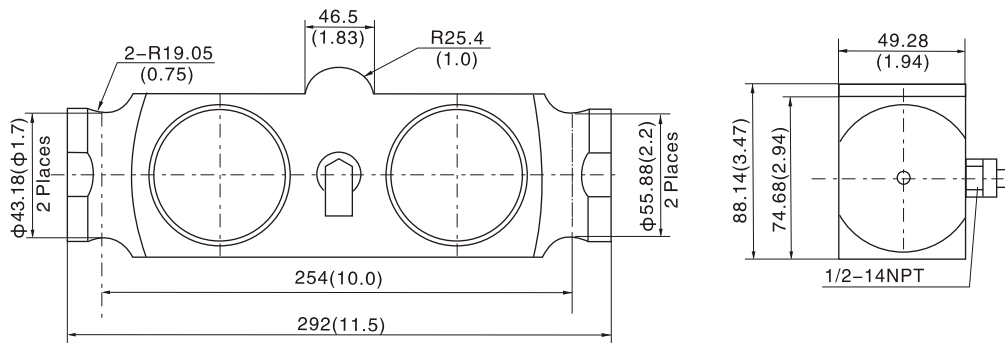

Wiring:

Adopt shielded, 4 conductor cable: Φ5mm
Standard cable length: 9m