

# B9F



- B9F load cells are available in the capacities 10Klb~75Klb.
- Stainless steel construction, potted by adhesive inside, oil proof, waterproof, anti-corrosive gas and medium making it suitable for all kinds of environments.
- Dual shear beam, suitable for electronic truck scales, hopper scales, track scales, and other electronic weighing devices.

### Features

- Capacity 10Klb~75Klb
- High accuracy
- Stainless steel construction,
- Easy installation and reliable performance

### Specifications

Capacity	Klb	10/15/20/25/30/40/50/60/75			
Accuracy		C2	C3	A5S	A5M
Maximum number of verification intervals	n <sub>max</sub>	2000	3000	5000	5000
Minimum load cell verification interval	v <sub>min</sub>	E <sub>max</sub> /5000	E <sub>max</sub> /10000	E <sub>max</sub> /15000	E <sub>max</sub> /15000
Combined error	(%FS)	≤ ±0.030	≤ ±0.020	≤ ±0.018	≤ ±0.026
Creep	(%FS/30min)	≤ ±0.024	≤ ±0.016	≤ ±0.012	≤ ±0.017
Temperature effect on sensitivity	(%FS/10°C)	≤ ±0.017	≤ ±0.011	≤ ±0.009	≤ ±0.013
Temperature effect on zero	(%FS/10°C)	≤ ±0.023	≤ ±0.015	≤ ±0.010	≤ ±0.014
Output sensitivity	(mv/v)	3.0±0.003			
Input resistance	(Ω)	700±7			
Output resistance	(Ω)	703±4			
Insulation resistance	(MΩ)	≥5000(50VDC)			
Zero balance	(%FS)	1.0			
Temperature, compensated	(°C)	-10~+40			
Temperature, operating	(°C)	-35~+65			
Excitation, recommended	(V)	5~12(DC)			
Excitation, max	(V)	18(DC)			
Safe overload	(%FS)	150			
Ultimate overload	(%FS)	300			

### Outline Dimension mm(inch)

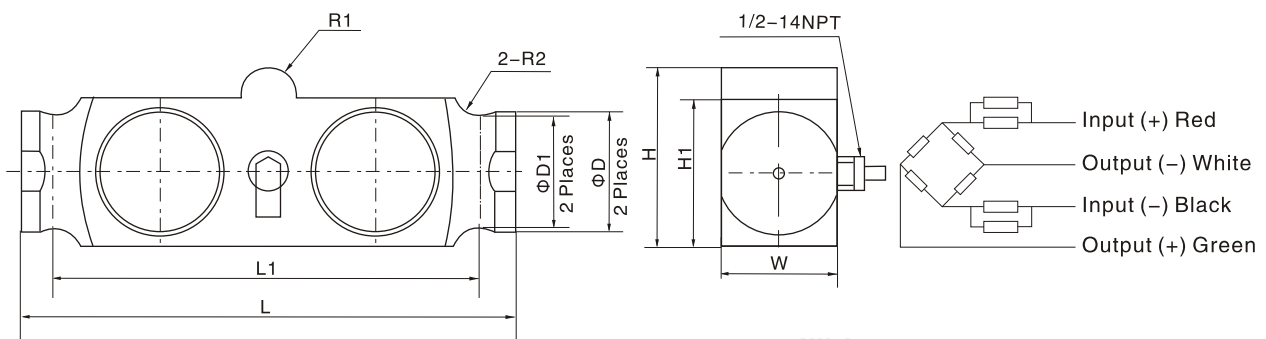

### Wiring:

Adopt shielded, 4 conductor cable: Φ5mm  
Standard cable length: 9m

Dimension Capacity	L	L1	H	H1	W	ΦD	ΦD1	R1	R2
10~25Klb	203.2 (8.0)	180.95 (7.12)	58.8 (2.31)	49.28 (1.94)	36.58 (1.44)	Φ25.4 (1.0)	Φ20.32 (0.8)	R9.52 (0.38)	R9.53 (0.37)
40~75Klb	215.9 (8.5)	184.15 (7.25)	76.12 (3.0)	62.23 (2.45)	49.53 (1.95)	Φ50.8 (2.0)	Φ44.45 (1.75)	R12.7 (0.5)	R19.05 (0.75)