



**Valve 2/2 way - angle seat/process valve N.C. -
Flow direction below the seat - pneumatically
operated - with electrical position indicators**

**21IA4T15GC2-IP1
÷
21IA9T50GC2-IP1**

PRESENTATION:

- High flow rate due to the angle seat configuration.
- Anti-water hammer feature with the fluid entry below the seat.
- Electrical operation is easy with the addition of a solenoid pilot.
- Stainless steel body and corrosion resistant actuator.
- The pneumatic actuator can be rotated through 360 degrees.
- Optical position indicator.
- Internal seals are self adjusting for long life.
- Easily convertible from N.C. to N.O. or double acting.
- Universal mounting - any mounting orientation is acceptable.

USE: Automation, Heating, Water, Hot water, Steam (180°C), Aggressive and food fluids

PIPES: G 1/2 - G 2

VALVE FEATURES:

Fluid Temperature - 40°C + 180°C
 Ambient temperature - 10°C + 80°C
 Viscosity of the fluid max 600 cSt
 Material Stainless steel AISI series 316
 Seal PTFE
 Packing gland PTFE, FKM

PILOT ACTUATOR FEATURES:

Fluid Dry Air or lubricated, gas and neutral fluids
 Fluid Temperature max + 60°C
 Body Polyamide 66 with 30% glass fibre
 Gaskets NBR
 Actuator Ø 70

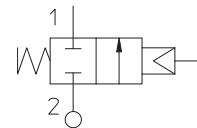

Pipe ISO 228/1	Code	Ø mm	Kv l/mn	Actuator pilot pressure (bar)		Differential pressure (bar)		Max. allowable pressure PS (bar)	Weight Kg
				min	max	min	max		
G 1/2	21IA4T15GC2-IP1	15	80	4	10	0	16	40	1,4
G 3/4	21IA5T20GC2-IP1	20	150				10		1,5
G 1	21IA6T25GC2-IP1	25	190				10		1,8
G 1 1/4	21IA7T32GC2-IP1	32	340				7	2,4	
G 1 1/2	21IA8T40GC2-IP1	40	430				4,5		2,7
G 2	21IA9T50GC2-IP1	50	620				3	16	3,9



CE Approval

(Pressure Equipment Directive 2014/68/EU)
for Valve 21IA7..-IP1 ÷ 21IA9..-IP1

Note

Available on request pilot S.V. 31A2AV20+BDA (see catalogue page) | Together with male thread nipple male G 1/4 - G 1/4 | Material compatibility with the fluids to be checked.

The "ODE" reserves the right to carry out technical and aesthetic modifications without prior notice.

MAINTENANCE KIT:

1.
 - G 1/2 R500045
 - G 3/4 R500048
 - G 1 R500051
 - G 1 1/4 R500054
 - G 1 1/2 R500057
 - G 2 R500060

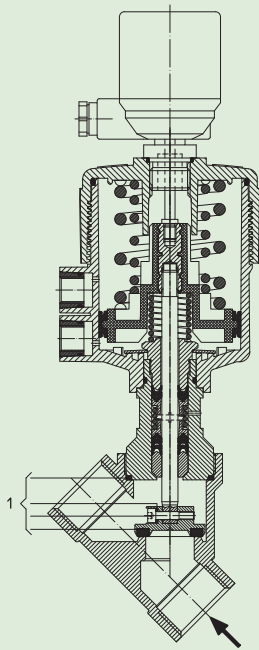

Connection diagram

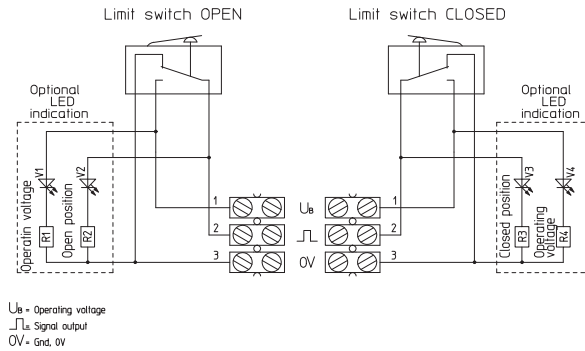

DIMENSIONS:

Pipe ISO 228/1	A mm	B mm	C mm	D mm	H mm	L mm	T mm
G 1/2	206,8	SW 27	178,7	15,4	163,3	65	17
G 3/4	211,7	SW 32	188,6	21,9	166,7	75,5	19
G 1	220,1	SW 41	197,8	25,1	172,7	90	21
G 1 1/4	235,9	SW 50	212,3	28,5	183,8	110	24
G 1 1/2	238,9	SW 55	217,0	31,0	186	122	25,2
G 2	247,8	SW 70	229,7	37,5	192,2	151	28,5

