

# Incremental encoders

**Standard**  
sine wave output, SIL2/PLd, optical

**Sendix SIL 5814FS2 / 5834FS2 (shaft / hollow shaft)**

**SinCos**

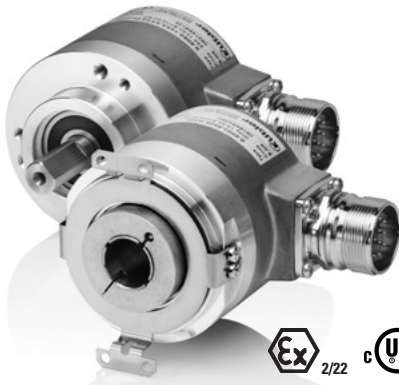

The incremental encoders 5814FS2 and 5834FS2 of the Sendix SIL family are suited for use in safety-related applications up to SIL2 according to EN 61800-5-2 or PLd according to EN ISO 13849-1.

These encoders are particularly suited for applications in the field of safe drive technology.



Safety-Lock™



High rotational speed



Temperature range



High protection level



High shaft load capacity



Shock / vibration resistant



Magnetic field proof



Reverse polarity protection

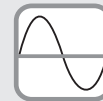

SinCos



Optical sensor

## Functional Safety

- Encoder with individual certificate from IFA / TÜV.
- Suitable for applications up to SIL2 acc. to EN 61800-5-2.
- Suitable for applications up to PLd acc. to EN ISO 13849-1.
- With incremental SinCos tracks.
- Certified mechanical mounting + electronic.

## Flexible

- Shaft and hollow shaft versions.
- Cable and connector variants.
- Various mounting options available.

**Order code**  
**Shaft version**

**8.5814FS2 . 1 XXXX . XXXX**  
Type                      a    b    c    d                      e

If for each parameter of an encoder the underlined preferred option is selected, then the delivery time will be 10 working days for a maximum of 10 pieces. Qts. up to 50 pcs. of these types generally have a delivery time of 15 working days.



### a Flange

1 = clamping flange, IP65, ø 58 mm [2.28"]

### b Shaft (ø x L)

2 = 10 x 20 mm [0.39 x 0.79"], with flat

A = 10 x 20 mm [0.39 x 0.79"], with feather key

### c Output circuit / power supply

1 = SinCos / 5 V DC

2 = SinCos / 10 ... 30 V DC

### d Type of connection

1 = axial cable, 1 m [3.28'] PVC

A = axial cable, special length PVC \*)

2 = radial cable, 1 m [3.28'] PVC

B = radial cable, special length PVC \*)

3 = axial M23 connector, 12 pin

4 = radial M23 connector, 12 pin

5 = axial M12 connector, 8 pin

6 = radial M12 connector, 8 pin

\*) Available special lengths (connection types A, B):  
2, 3, 5, 8, 10, 15 m [6.56, 9.84, 16.40, 26.25, 32.80, 49.21']  
order code expansion .XXXX = length in dm  
ex.: 8.5814FS2.122A.2048.0030 (for cable length 3 m)

### e Pulse rate

1024, 2048

Optional on request

- Ex 2/22 <sup>1)</sup>

1) For the cable connection type, cable material PUR.

# Incremental encoders

<b>Standard</b> sine wave output, SIL2/PLd, optical	<b>Sendix SIL 5814FS2 / 5834FS2 (shaft / hollow shaft)</b>	<b>SinCos</b>
--	--	---------------

<b>Order code</b> Hollow shaft	<b>8.5834FS2</b> Type	<b>. X X X X . X X X X</b> a b c d e	If for each parameter of an encoder the <u>underlined preferred option</u> is selected, then the delivery time will be 10 working days for a maximum of 10 pieces. Qts. up to 50 pcs. of these types generally have a delivery time of 15 working days.	<b>10 By 10</b>
-----------------------------------	--------------------------	---	--	-----------------

<p><b>a</b> Flange 9 = with torque stop, flexible, IP65 A = with torque stop set, rigid, IP65 <b>B = with stator coupling, IP65, ø 63 mm [2.48"]</b></p> <p><b>b</b> Hollow shaft 3 = ø 10 mm [0.39"] <b>4 = ø 12 mm [0.47"]</b> 5 = ø 14 mm [0.55"] K = ø 10 mm [0.39"], tapered shaft</p> <p><b>c</b> Output circuit / power supply 1 = SinCos / 5 V DC <b>2 = SinCos / 10 ... 30 V DC</b></p>	<p><b>d</b> Type of connection 2 = radial cable, 1 m [3.28'] PVC B = radial cable, special length PVC *) E = tangential cable, 1 m [3.28'] PVC F = tangential cable, special length PVC *) <b>4 = radial M23 connector, 12 pin</b> 6 = radial M12 connector, 8 pin</p> <p>*) Available special lengths (connection types B, F): 2, 3, 5, 8, 10, 15 m [6.56, 9.84, 16.40, 26.25, 32.80, 49.21'] order code expansion .XXXX = length in dm ex.: 8.5834FS2.B42B.2048.0030 (for cable length 3 m)</p>	<p><b>e</b> Pulse rate 1024, <b>2048</b></p> <p><i>Optional on request</i> - Ex 2/22 (not for connection type E + F) <sup>1)</sup></p>
--	---	--

Accessories		Order no.
<b>EMC shield terminal</b>	for top-hat rail mounting	<b>8.0000.4G06.0000</b>
<b>Screw retention</b>	Loctite 243, 5 ml	<b>8.0000.4G05.0000</b>
<b>Bellows coupling, safety-oriented</b>	You will find an overview of our couplings for Sendix SIL shaft encoders in the accessories section or under <a href="http://www.kuebler.com/accessories">www.kuebler.com/accessories</a> .	
<b>Safety modules Safety-M compact / modular</b>	You will find an overview of our systems and components for Functional Safety and the corresponding software in the safety technology section or under <a href="http://www.kuebler.com/safety">www.kuebler.com/safety</a> .	

Further accessories can be found in the accessories section or in the accessories area of our website at: [www.kuebler.com/accessories](http://www.kuebler.com/accessories).

Connection technology		Order no.
<b>Cordset, pre-assembled</b>	M12 female connector with coupling nut – single-ended, 2 m [6.56'] PVC cable <sup>2)</sup>	<b>05.00.6041.8211.002M</b>
	M23 female connector with coupling nut – single-ended, 2 m [6.56'] PVC cable <sup>2)</sup>	<b>8.0000.6901.0002</b>
<b>Connector, self-assembly (straight)</b>	M12 female connector with coupling nut	<b>05.CMB 8181-0</b>
	M23 female connector with coupling nut	<b>8.0000.5012.0000</b>

Additional connectors can be found in the connection technology section or in the connection technology area of our website at: [www.kuebler.com/connection\\_technology](http://www.kuebler.com/connection_technology).

## Technical data

Notes regarding "Functional Safety"
These encoders are suitable for use in safety-related systems up to SIL2 acc. to EN 61800-5-2 and PLd to EN ISO 13849-1 in conjunction with controllers or evaluation units, which possess the necessary functionality. Additional functions can be found in the operating manual.

Safety characteristics	
<b>Classification</b>	PLd / SIL2
<b>System structure</b>	2 channel (Cat. 3 / HFT = 1)
<b>PFH<sub>d</sub> value <sup>3)</sup></b>	2.16 x 10 <sup>-8</sup> h <sup>-1</sup>
<b>Mission time / Proof test interval</b>	20 years
<b>Relevant standards</b>	EN ISO 13849-1:2008; EN ISO 13849-2:2013; EN 61800-5-2:2007

1) For the cable connection type, cable material PUR.  
2) Other lengths available.  
3) The specified value is based on a diagnostic coverage of 90 %, that must be achieved with an encoder evaluation unit.  
The encoder evaluation unit must meet at least the requirements for SIL2

Incremental encoders

# Incremental encoders

<b>Standard sine wave output, SIL2/PLd, optical</b>	<b>Sendix SIL 5814FS2 / 5834FS2 (shaft / hollow shaft)</b>	<b>SinCos</b>
---	--	---------------

Mechanical characteristics		
<b>Maximum speed, shaft version</b>	up to 70°C [158°F]	12000 min <sup>-1</sup> , 10000 min <sup>-1</sup> (continuous)
	up to T <sub>max</sub>	8000 min <sup>-1</sup> , 5000 min <sup>-1</sup> (continuous)
<b>Maximum speed, hollow shaft version</b>	up to 70°C [158°F]	9000 min <sup>-1</sup> , 6000 min <sup>-1</sup> (continuous)
	up to T <sub>max</sub>	6000 min <sup>-1</sup> , 3000 min <sup>-1</sup> (continuous)
<b>Starting torque – at 20°C [68°F]</b>	shaft version	< 0.01 Nm
	hollow shaft version	< 0.03 Nm
<b>Mass moment of inertia</b>	shaft version	4.0 x 10 <sup>-6</sup> kgm <sup>2</sup>
	hollow shaft version	7.0 x 10 <sup>-6</sup> kgm <sup>2</sup>
<b>Insertion depth for shaft</b>	hollow shaft version	min. 34 mm [1.34"]
<b>Load capacity of shaft</b>	radial	80 N
	axial	40 N
<b>Weight</b>		approx. 0.45 kg [15.87 oz]
<b>Protection acc. to EN 60529</b>		IP65
<b>Working temperature range</b>		-40°C ... +90°C [-40°F ... +194°F] <sup>1)</sup>
<b>Materials</b>	shaft / hollow shaft	stainless steel
	flange	aluminium
	housing	zinc die-cast
	cable	PVC
<b>Shock resistance acc. to EN 60068-2-27</b>		500 m/s <sup>2</sup> , 11 ms
<b>Vibration resistance acc. to EN 60068-2-6</b>		200 m/s <sup>2</sup> , 10 ... 150 Hz

Electrical characteristics	
<b>Power supply</b>	5 V DC (±5 %) or 10 ... 30 V DC
<b>Power consumption (no load)</b>	5 V DC max. 70 mA 10 ... 30 V DC max. 45 mA
<b>Reverse polarity protection of the power supply</b>	yes
<b>Short circuit proof outputs</b>	yes <sup>2)</sup>
<b>UL approval</b>	file 224618
<b>CE compliant acc. to</b>	EMC guideline 2014/30/EU Machinery directive 2006/42/EC RoHS guideline 2011/65/EU

EMC	
<b>Relevant standards</b>	EN 55011 class B :2009 / A1:2010 EN 61000-6-3:2007 / A1:2011 EN 61000-6-2:2005

SinCos interface	
<b>Max. frequency -3dB</b>	400 kHz
<b>Signal level</b>	1 V <sub>pp</sub> (±10 %)
<b>Short circuit proof</b>	yes <sup>2)</sup>
<b>Pulse rate</b>	1024 / 2048 ppr

## Terminal assignment

Output circuit	Type of connection	Cable (isolate unused wires individually before initial start-up)								
1, 2	1, 2, A, B, E, F	Signal:	0 V	+V	A	$\bar{A}$	B	$\bar{B}$	$\perp$	
		Cable colour:	WH	BN	GN	YE	GY	PK	shield	
1, 2	3, 4	M23 connector, 12-pin								
		Signal:	0 V	+V	A	$\bar{A}$	B	$\bar{B}$	$\perp$	
		Pin:	10	12	5	6	8	1	PH <sup>3)</sup>	
1, 2	5, 6	M12 connector, 8-pin								
		Signal:	0 V	+V	A	$\bar{A}$	B	$\bar{B}$	$\perp$	
		Pin:	1	2	3	4	5	6	PH <sup>3)</sup>	

- +V: Encoder power supply +V DC
- 0 V: Encoder power supply ground GND (0 V)
- A,  $\bar{A}$ : Cosine signal
- B,  $\bar{B}$ : Sine signal
- PH  $\perp$ : Plug connector housing (shield)

## Top view of mating side, male contact base

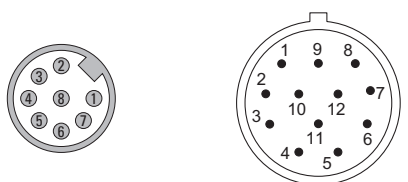

M12 connector, 8-pin

M23 connector, 12-pin

1) Cable version: -30°C ... +90°C [-22°F ... +194°F] fixed installation.  
 2) Short circuit to 0 V or to output, one channel at a time, power supply correctly applied.  
 3) PH  $\perp$  = shield is attached to connector housing.

# Incremental encoders

<b>Standard</b> sine wave output, SIL2/PLd, optical	<b>Sendix SIL 5814FS2 / 5834FS2 (shaft / hollow shaft)</b>	<b>SinCos</b>
--	--	---------------

## Dimensions shaft version

Dimensions in mm [inch]

**Clamping flange,  $\varnothing$  58 [2.28]**  
**Flange type 1 with shaft type 2**  
 (drawing with cable)

- 1 3 x M3, 6 [0.24] deep
- 2 3 x M4, 8 [0.32] deep
- D = 10<sup>17</sup> [0.39]

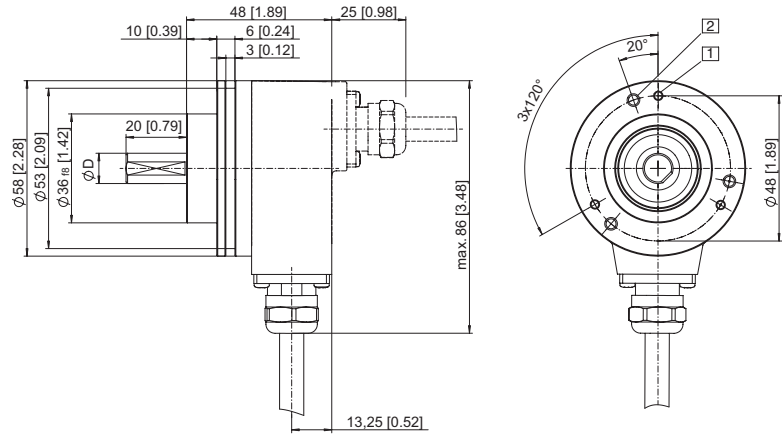

**Clamping flange,  $\varnothing$  58 [2.28]**  
**Flange type 1 with shaft type A**  
 (drawing with M23 connector)

- 1 3 x M3, 6 [0.24] deep
- 2 3 x M4, 8 [0.32] deep
- 3 Feather key DIN 6885 - A - 3x3x6
- D = 10<sup>17</sup> [0.39]

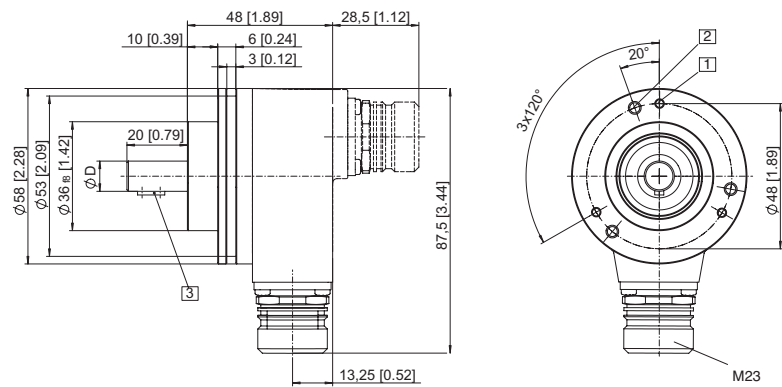

(drawing with M12 connector)

- 1 3 x M3, 6 [0.24] deep
- 2 3 x M4, 8 [0.32] deep
- 3 Feather key DIN 6885 - A - 3x3x6
- D = 10<sup>17</sup> [0.39]

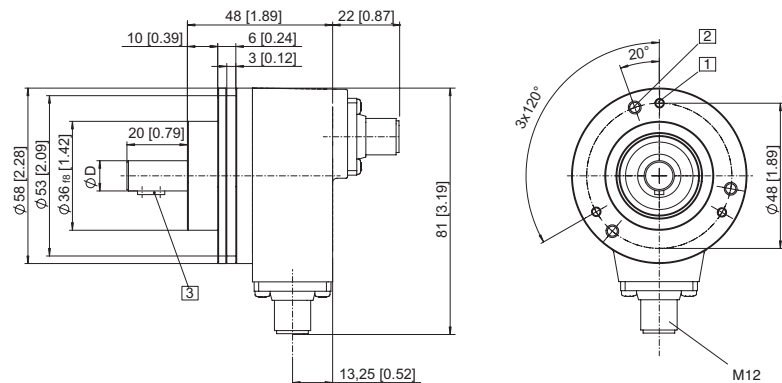

# Incremental encoders

**Standard**  
sine wave output, SIL2/PLd, optical

**Sendix SIL 5814FS2 / 5834FS2 (shaft / hollow shaft)**

**SinCos**

## Dimensions hollow shaft version

Dimensions in mm [inch]

**Flange with torque stop set, rigid**  
**Flange type A**  
**Through hollow shaft**  
(drawing with cable)

- 1 SW 3,  
recommended torque for the  
clamping ring 2.5 Nm
- $D = \emptyset 10^{H7}$  [0.39]
- $\emptyset 12^{H7}$  [0.47]
- $\emptyset 14^{H7}$  [0.55]

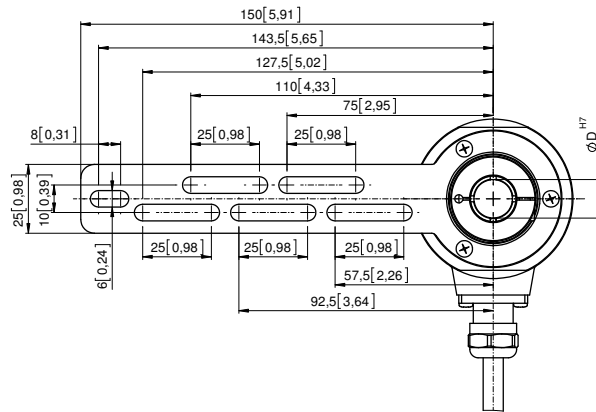
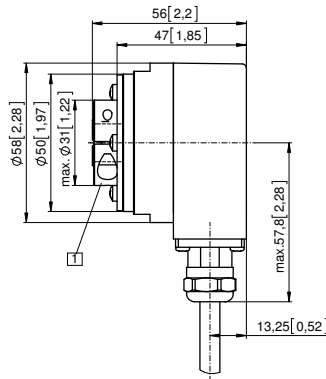

(drawing with M12 connector)

- 1 SW 3,  
recommended torque for the  
clamping ring 2.5 Nm
- $D = \emptyset 10^{H7}$  [0.39]
- $\emptyset 12^{H7}$  [0.47]
- $\emptyset 14^{H7}$  [0.55]

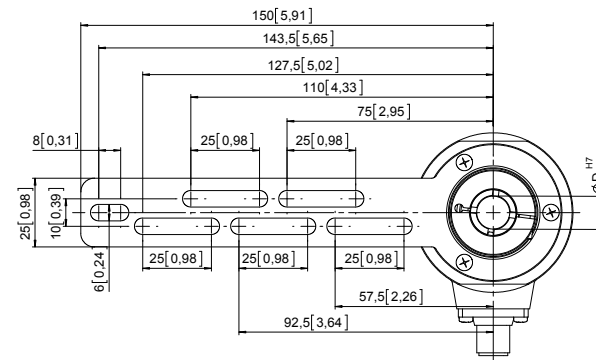
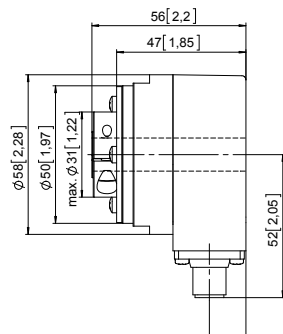

Torque pin with rectangular sleeve  
with M4 thread

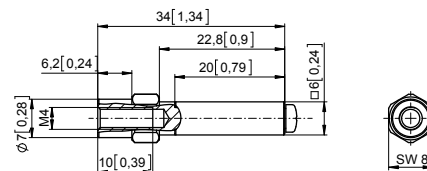

**Flange with torque stop, flexible**  
**Flange type 9**  
**Through hollow shaft**  
(drawing with M23 connector)

- 1 Recommended torque for the  
clamping ring 2.5 Nm
- $D = \emptyset 10^{H7}$  [0.39]
- $\emptyset 12^{H7}$  [0.47]
- $\emptyset 14^{H7}$  [0.55]

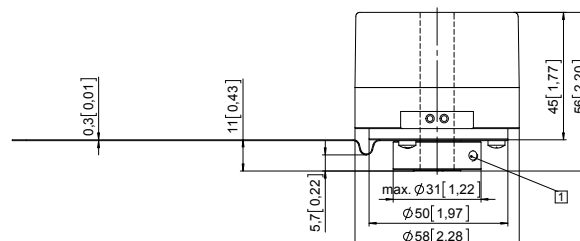
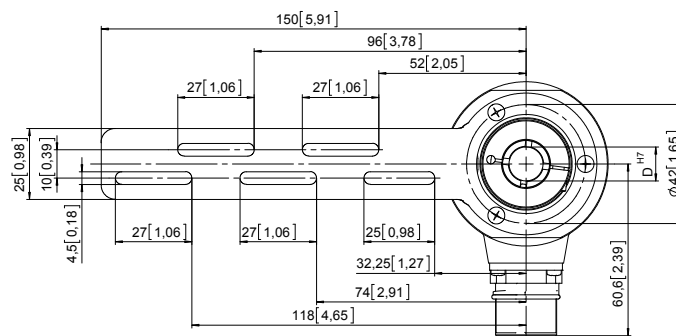

# Incremental encoders

<b>Standard</b> sine wave output, SIL2/PLd, optical	<b>Sendix SIL 5814FS2 / 5834FS2 (shaft / hollow shaft)</b>	<b>SinCos</b>
--	--	---------------

## Dimensions hollow shaft version

Dimensions in mm [inch]

### Flange with stator coupling, ø 63 [2.48]

#### Flange type B

#### Through hollow shaft

(drawing with M23 connector)

- 1 SW 3,  
recommended torque for the  
clamping ring 2.5 Nm
  - 2 For (4x) M3 screw
- D = ø 10<sup>H7</sup> [0.39]  
 ø 12<sup>H7</sup> [0.47]  
 ø 14<sup>H7</sup> [0.55]

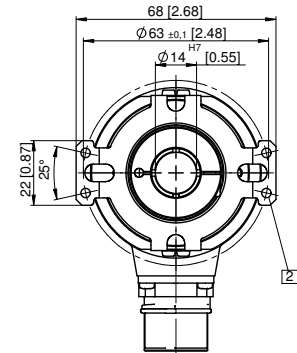
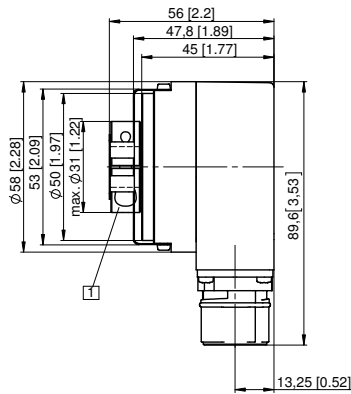

Incremental encoders

### Flange with stator coupling, ø 63 [2.48]

#### Flange type B

#### Tapered shaft

(drawing with tangential cable outlet)

- 1 For (4x) M3 screw
- 2 Status LED
- 3 SET button
- 4 SW 4

