

Tumbler bearings 30 t to 50 t



Description

Tecsis installed parts for load cells are so designed that an optimum force application occurs in the load cell. The self-aligning bearing AZK01X712 in conjunction with the high capacity load cell F1270 forms a self-centring unit which has low height.

The unit is secured with screws.

An installation gauge is available to make the installation of the base plate simple and accurate.

By means of the optional special spirit level the load cells can be set up exactly vertical.

Features

- Supply kit:
 - 2 hardened thrust pieces with O-ring;
 - 2 retaining plates;
 - 2 clamps;
 - bridging cable;
 - 1 set of assembly screws
- Cost-effective
- Simple installation
- Specially designed for vehicle weighing machines
- Optional accessories:
 - Built-in gauge;
 - Special water weighing scales;
 - Sealing plate

Measuring ranges

- For nominal loads of 30 t, 40 t and 50 t

Applications

- For force transducers of the models F1270

Material

- Standard: Steel, galvanised

Model: AZK01X712

Dimensional drawing

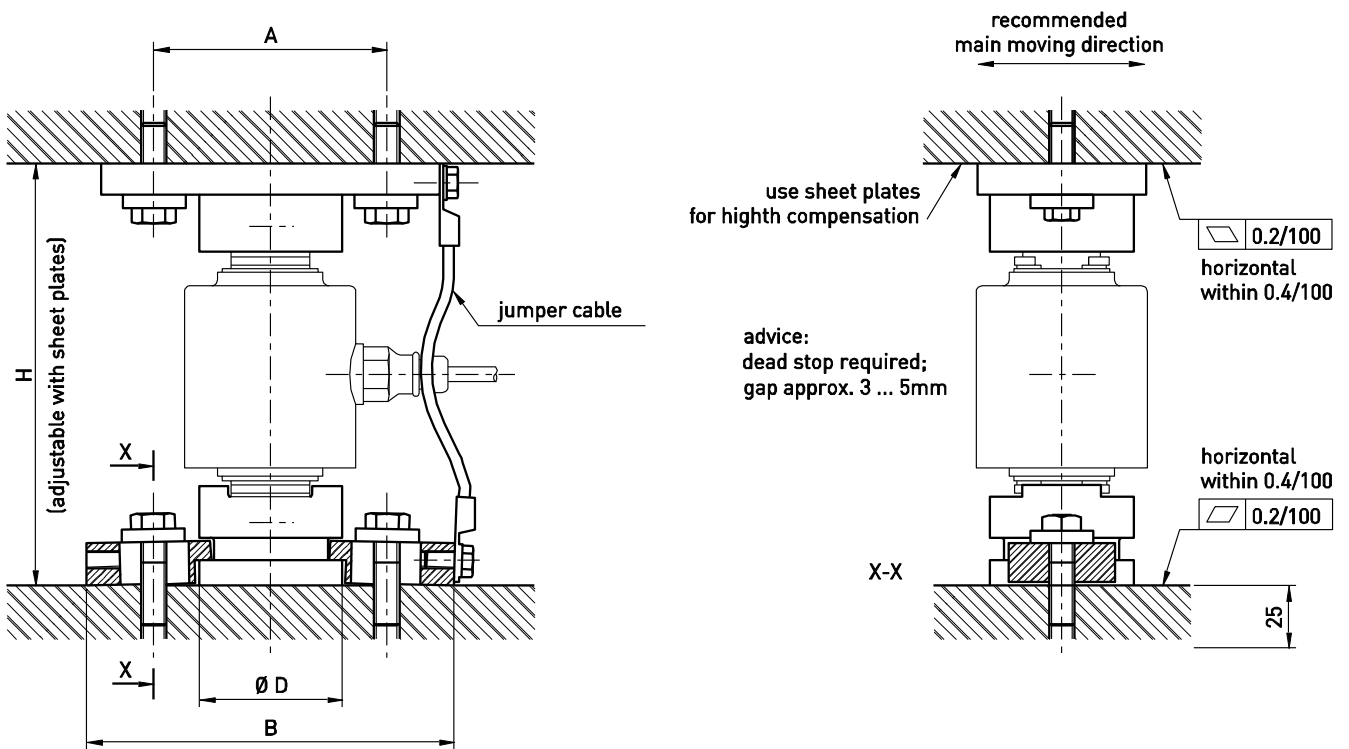

Load cell	Dimensions (mm)			
	A	B	D	H
F1270-30 t	110	176	68	200 / 210
F1270-40 t	110	176	68	210
F1270-50 t	130	196	88	240

Accessories (optional)

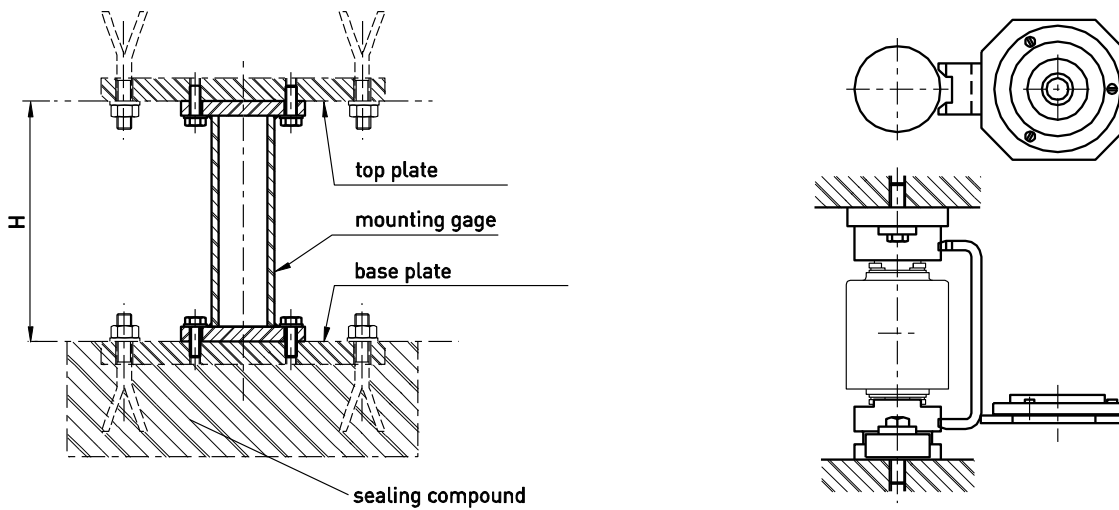

Subject of technical changes