

Accessory

# BY-14-109

Capacity	Part number
10t, 15t	BY-14-109-10/15t
20t-40t	BY-14-109-20/40t
50t, 60t	BY-14-109-50/60t
100t	BY-14-109-100t

**Features:**

Easy installation, good self-aligning ability, anti-reversal ability.  
Stainless steel construction, anti-corrosion, can be used under hazardous environments.  
Mainly used for platform scales, automobile testing facilities, electronic truck scales and other electronic weighing devices.



Stainless steel, assembled with: BM14K-WI  
Locating pin on the bottom plate is for anti-rotation occasion.

Outline Dimension mm(inch)

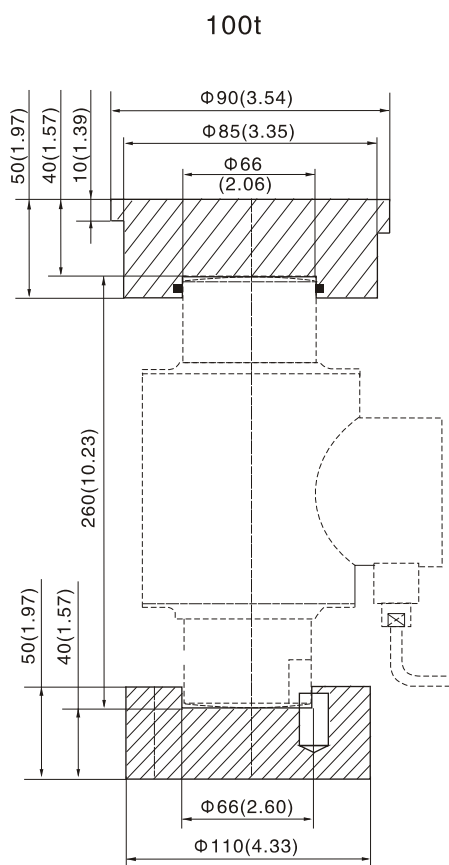
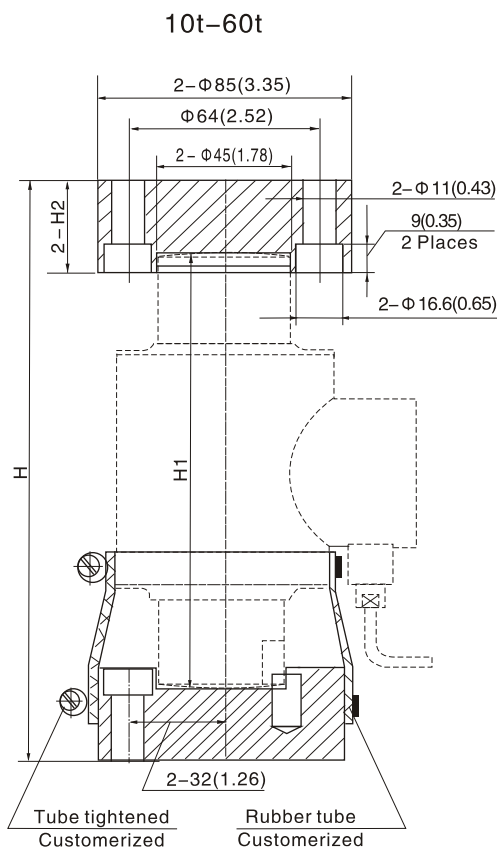

Locating circle can be offered on requests.

Eccentric washer, Φ165(6.5) Customized

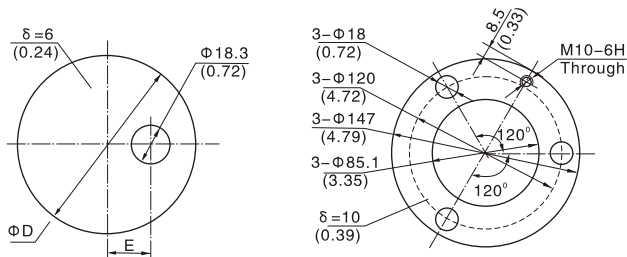

Dimension Capacity	10t,15t	20t-40t	50t,60t	100t
H	160(6.3)	200(7.87)	260(10.24)	See pictures
H1	130(5.12)	150(5.91)	210(8.27)	See pictures
H2	22(0.87)	32(1.26)	32(1.26)	See pictures
D	80(3.15)	80(3.15)	80(3.15)	55(2.17)
W	18.9(0.74)	18.9(0.74)	18.9(0.74)	14(0.55)