

## ZAWORY ROZDZIELAJĄCE 3/2, 3/3, 5/2, 5/3 G1/8 ÷ G3/4 zasilane przewodowo i płytowo, sterowane pneumatycznie, bezsmarowe Seria DTP





### ZASTOSOWANIE

Zawory rozdzielające służą do sterowania elementami wykonawczymi (np. siłownikami) w pneumatycznych układach napędowych i sterujących.

### DANE TECHNICZNE

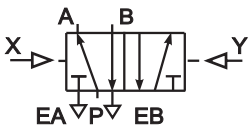
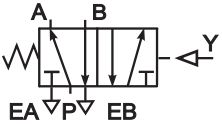
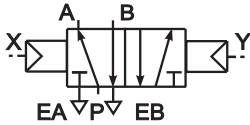
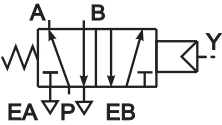
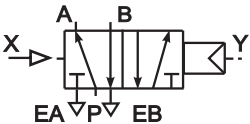
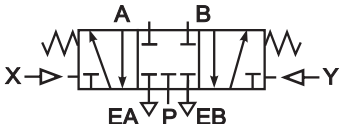
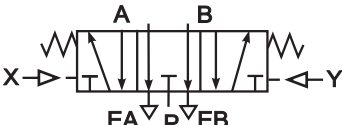
Czynnik roboczy:	Sprężone powietrze lub inny gaz techniczny neutralny w stosunku do użytych materiałów konstrukcyjnych	
Zakres ciśnień pracy dla:		
– zaworów 3/2, 5/2 sterowanych pneumatycznie		0.2 ÷ 1.0 MPa
– zaworów 3/2, 5/2 sterowanych pneumatycznie powrót sprężyną		0.3 ÷ 1.0 MPa
– zaworów 3/3, 5/3 sterowanych pneumatycznie		0.3 ÷ 1.0 MPa
– zaworów 3/2, 5/2 sterowanych pneumatycznie sygnałem niskociśnieniowym		0.15 ÷ 1.0 MPa
Zakres temperatur pracy:	od 0 do 65°C	
Pozycja pracy:	dowolna	
Rodzaj konstrukcji:	suwakowy	
Kierunek przepływu:	zgodnie ze schematem	
Sposób zasilania:	przewodowo lub płytowo, sprężonym powietrzem o maksymalnej wielkości cząstek stałych 40 µm, smarowanym mgłą olejową 2 ÷ 5 kropli/m <sup>3</sup> lub przewodowo sprężonym powietrzem o maksymalnej wielkości cząstek stałych 10 µm (nie wymaga smarowania)	
Materiały konstrukcyjne:	<b>Korpus, suwak</b> - stop aluminium <b>Pokrywy</b> - stop ZnAl <b>Uszczelnienia</b> - poliuretan PU	

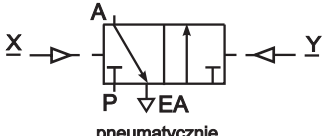
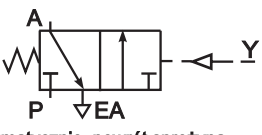
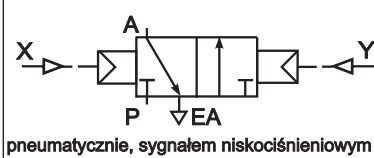
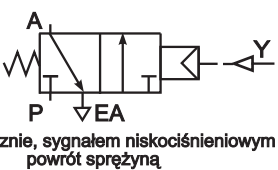
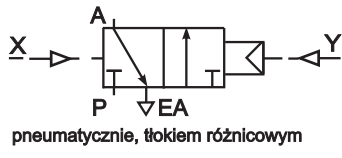
Funkcja zaworu	Symbol graficzny rodzaj sterowania	Sposób zasilania	Gwint przyłącza	Średnica nominalna zaworu [mm]	Numer zamówieniowy	
					zaworu DTP	plyty przyłączeniowej
5/2	 <p>pneumatycznie</p>	przewodowy	G1/8	∅ 5	23.0101.5218	-
			G1/4	∅ 7.5	23.0101.5214	-
		plytowy	G1/8	∅ 7.5	23.0102.521814	25.0102.525318P
			G1/4			25.0102.525314P
			G1/4	∅ 12	23.0102.521438	25.0103.525314P
			G3/8			25.0103.525338P
	G1/2	∅ 20	23.0102.521234	25.0104.525312P		
	G3/4			25.0104.525334P		
	 <p>pneumatycznie, powrót sprężyną</p>	przewodowy	G1/8	∅ 5	23.0103.5218	-
			G1/4	∅ 7.5	23.0103.5214	-
		plytowy	G1/8	∅ 7.5	23.0104.521814	25.0102.525318P
			G1/4			25.0102.525314P
			G1/4	∅ 12	23.0104.521438	25.0103.525314P
			G3/8			25.0103.525338P
	G1/2	∅ 20	23.0104.521234	25.0104.525312P		
	G3/4			25.0104.525334P		
	 <p>pneumatycznie, sygnałem niskociśnieniowym</p>	przewodowy	G1/8	∅ 5	23.0107.5218	-
			G1/4	∅ 7.5	23.0107.5214	-
		plytowy	G1/8	∅ 7.5	23.0108.521814	25.0102.525318P
			G1/4			25.0102.525314P
			G1/4	∅ 12	23.0108.521438	25.0103.525314P
			G3/8			25.0103.525338P
	G1/2	∅ 20	23.0108.521234	25.0104.525312P		
	G3/4			25.0104.525334P		
 <p>pneumatycznie, sygnałem niskociśnieniowym powrót sprężyną</p>	przewodowy	G1/8	∅ 5	23.0109.5218	-	
		G1/4	∅ 7.5	23.0109.5214	-	
	plytowy	G1/8	∅ 7.5	23.0110.521814	25.0102.525318P	
		G1/4			25.0102.525314P	
		G1/4	∅ 12	23.0110.521438	25.0103.525314P	
		G3/8			25.0103.525338P	
G1/2	∅ 20	23.0110.521234	25.0104.525312P			
G3/4			25.0104.525334P			
 <p>pneumatycznie, tłokiem różnicowym</p>	przewodowy	G1/8	∅ 5	23.0105.5218	-	
		G1/4	∅ 7.5	23.0105.5214	-	
	plytowy	G1/8	∅ 7.5	23.0106.521814	25.0102.525318P	
		G1/4			25.0102.525314P	
		G1/4	∅ 12	23.0106.521438	25.0103.525314P	
		G3/8			25.0103.525338P	
G1/2	∅ 20	23.0106.521234	25.0104.525312P			
G3/4			25.0104.525334P			
5/3	 <p>pneumatycznie, w położeniu środkowym wszystkie drogi odcięte</p>	przewodowy	G1/8	∅ 5	23.0111.5318	-
			G1/4	∅ 7.5	23.0111.5314	-
		plytowy	G1/8	∅ 7.5	23.0112.531814	25.0102.525318P
			G1/4			25.0102.525314P
			G1/4	∅ 12	23.0112.531438	25.0103.525314P
			G3/8			25.0103.525338P
	G1/2	∅ 20	23.0112.531234	25.0104.525312P		
	G3/4			25.0104.525334P		
	 <p>pneumatycznie, w położeniu środkowym odbiorniki połączone z atmosferą</p>	przewodowy	G1/8	∅ 5	23.0113.5318	-
			G1/4	∅ 7.5	23.0113.5314	-
		plytowy	G1/8	∅ 7.5	23.0114.531814	25.0102.525318P
			G1/4			25.0102.525314P
G1/4			∅ 12	23.0114.531438	25.0103.525314P	
G3/8					25.0103.525338P	
G1/2	∅ 20	23.0114.531234	25.0104.525312P			
G3/4			25.0104.525334P			

Funkcja zaworu	Symbol graficzny rodzaj sterowania	Sposób zasilania	Gwint przyłącza	Średnica nominalna zaworu [mm]	Numer zamówieniowy	
					zaworu DTP	płyty przyłączeniowej
<b>3/2</b>	 pneumatycznie	przewodowy	G1/8	∅ 5	23.0101.3218	-
			G1/4	∅ 7.5	23.0101.3214	-
		płyty	G1/4	∅ 7.5	23.0102.3214	<b>25.0101.323314P</b>
			G3/8	∅ 12	23.0102.3238	<b>25.0101.323338P</b>
			G1/2	∅ 16	23.0102.3212	<b>25.0101.323312P</b>
			G3/4	∅ 20	23.0102.3234	<b>25.0101.323334P</b>
	 pneumatycznie, powrót sprężyną	przewodowy	G1/8	∅ 5	23.0103.3218	-
			G1/4	∅ 7.5	23.0103.3214	-
		płyty	G1/4	∅ 7.5	23.0104.3214	<b>25.0101.323314P</b>
			G3/8	∅ 12	23.0104.3238	<b>25.0101.323338P</b>
			G1/2	∅ 16	23.0104.3212	<b>25.0101.323312P</b>
			G3/4	∅ 20	23.0104.3234	<b>25.0101.323334P</b>
	 pneumatycznie, sygnałem niskociśnieniowym	przewodowy	G1/8	∅ 5	23.0107.3218	-
			G1/4	∅ 7.5	23.0107.3214	-
		płyty	G1/4	∅ 7.5	23.0108.3214	<b>25.0101.323314P</b>
			G3/8	∅ 12	23.0108.3238	<b>25.0101.323338P</b>
			G1/2	∅ 16	23.0108.3212	<b>25.0101.323312P</b>
			G3/4	∅ 20	23.0108.3234	<b>25.0101.323334P</b>
	 pneumatycznie, sygnałem niskociśnieniowym powrót sprężyną	przewodowy	G1/8	∅ 5	23.0109.3218	-
			G1/4	∅ 7.5	23.0109.3214	-
		płyty	G1/4	∅ 7.5	23.0110.3214	<b>25.0101.323314P</b>
			G3/8	∅ 12	23.0110.3238	<b>25.0101.323338P</b>
			G1/2	∅ 16	23.0110.3212	<b>25.0101.323312P</b>
			G3/4	∅ 20	23.0110.3234	<b>25.0101.323334P</b>
 pneumatycznie, tłokiem różnicowym	przewodowy	G1/8	∅ 5	23.0105.3218	-	
		G1/4	∅ 7.5	23.0105.3214	-	
	płyty	G1/4	∅ 7.5	23.0106.3214	<b>25.0101.323314P</b>	
		G3/8	∅ 12	23.0106.3238	<b>25.0101.323338P</b>	
		G1/2	∅ 16	23.0106.3212	<b>25.0101.323312P</b>	
		G3/4	∅ 20	23.0106.3234	<b>25.0101.323334P</b>	
<b>3/3</b>	 pneumatycznie, w położeniu środkowym wszystkie drogi odcięte	przewodowy	G1/8	∅ 5	23.0111.3318	-
			G1/4	∅ 7.5	23.0111.3314	-
		płyty	G1/4	∅ 7.5	23.0112.3314	<b>25.0101.323314P</b>
			G3/8	∅ 12	23.0112.3338	<b>25.0101.323338P</b>
			G1/2	∅ 16	23.0112.3312	<b>25.0101.323312P</b>
			G3/4	∅ 20	23.0112.3334	<b>25.0101.323334P</b>

SPOSÓB ZAMAWIANIA

W zamówieniu należy podać: nazwę i funkcję zaworu, gwint przyłącza, numer zamówieniowy oraz ilość sztuk np:

**Zawór rozdzielający 5/2 sterowany pneumatycznie powrót sprężyną, G3/8, płytowy nr 23.0104.521438 3 szt.**

ZAWÓR ROZDZIAJĄCY 3/2 - STEROWANY PNEUMATYCZNIE

ZASILANY PRZEWODOWO

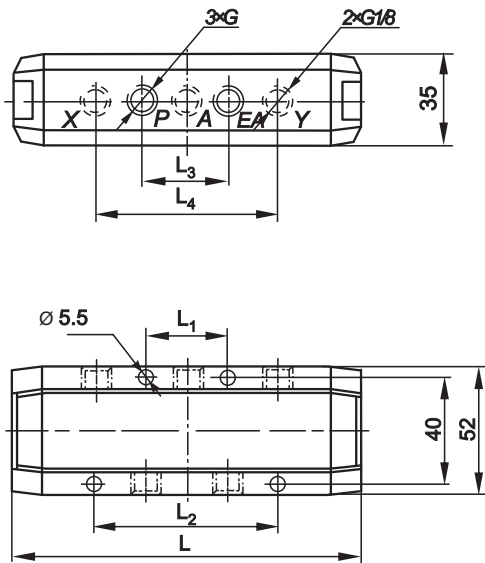

G	L	L <sub>1</sub>	L <sub>2</sub>	L <sub>3</sub>	L <sub>4</sub>
G1/8	117	26	48	22	43
G1/4	132	34	66	32	58

ZASILANY PŁYTOWO

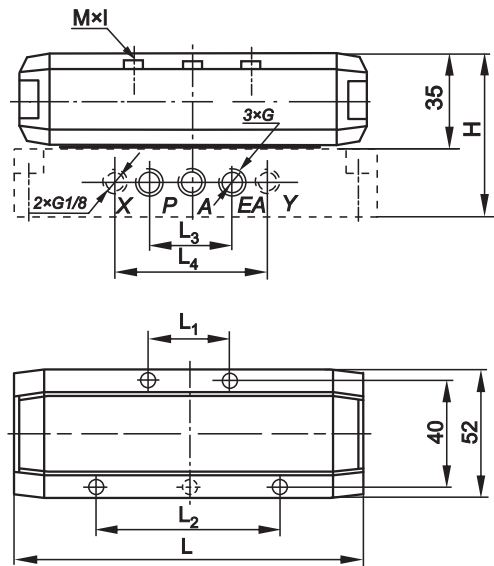

G	H	L	L <sub>1</sub>	L <sub>2</sub>	L <sub>3</sub>	L <sub>4</sub>	M x I
G1/4	59	117	26	48	26	52	M5x40-4szt
G3/8	64	132	34	66	35	66	M5x40-4szt
G1/2	69	147	39	81	48	88	M5x40-4szt
G3/4	74	172	52	92	52	104	M5x50-5szt

ZAWÓR ROZDZIAJĄCY 5/2 - STEROWANY PNEUMATYCZNIE

ZASILANY PRZEWODOWO

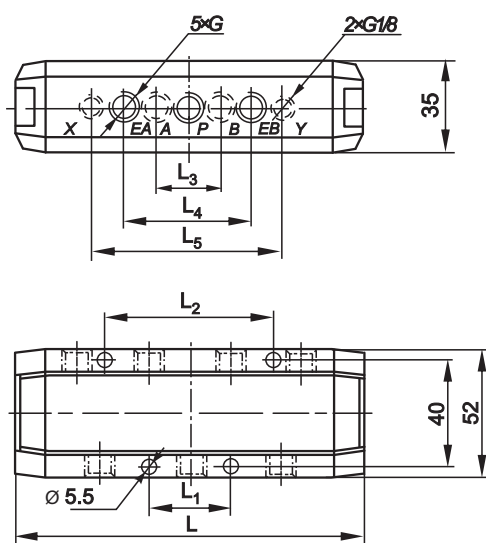

G	L	L <sub>1</sub>	L <sub>2</sub>	L <sub>3</sub>	L <sub>4</sub>	L <sub>5</sub>
G1/8	139	22	44	22	44	65
G1/4	164	32	62	32	64	90

ZASILANY PŁYTOWO

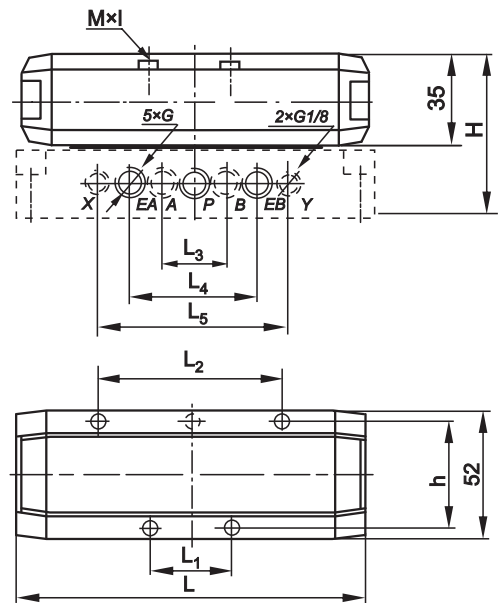

G	H	L	L <sub>1</sub>	L <sub>2</sub>	L <sub>3</sub>	L <sub>4</sub>	L <sub>5</sub>	h	M x I
G1/8-G1/4	59	139	34	60	26	56	82	40	M5x40-4szt
G1/4-G3/8	65	164	48	86	35	70	112	42	M5x40-4szt
G1/2-G3/4	73	224	52	104	52	104	144	40	M6x40-5szt

ZAWÓR ROZDZIELAJĄCY 3/2 - STEROWANY PNEUMATYCZNIE POWRÓT SPRĘŻYNĄ

ZASILANY PRZEWODOWO

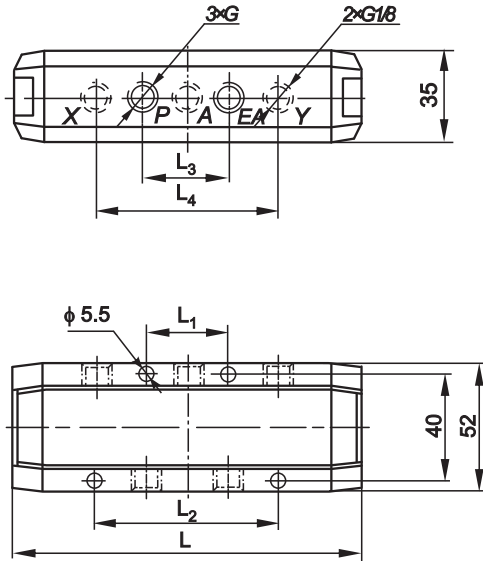

G	L	L <sub>1</sub>	L <sub>2</sub>	L <sub>3</sub>	L <sub>4</sub>
G1/8	117	26	48	22	43
G1/4	132	34	66	32	58

ZASILANY PŁYTKOWO

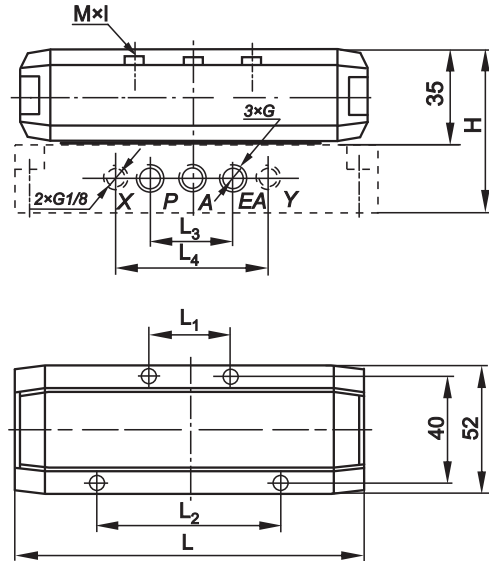

G	H	L	L <sub>1</sub>	L <sub>2</sub>	L <sub>3</sub>	L <sub>4</sub>	M × I
G1/4	59	117	26	48	26	52	M5×40-4szt
G3/8	64	132	34	66	35	66	M5×40-4szt
G1/2	69	147	39	81	48	88	M5×40-4szt
G3/4	74	172	52	92	52	104	M5×50-5szt

ZAWÓR ROZDZIELAJĄCY 5/2 - STEROWANY PNEUMATYCZNIE POWRÓT SPRĘŻYNĄ

ZASILANY PRZEWODOWO

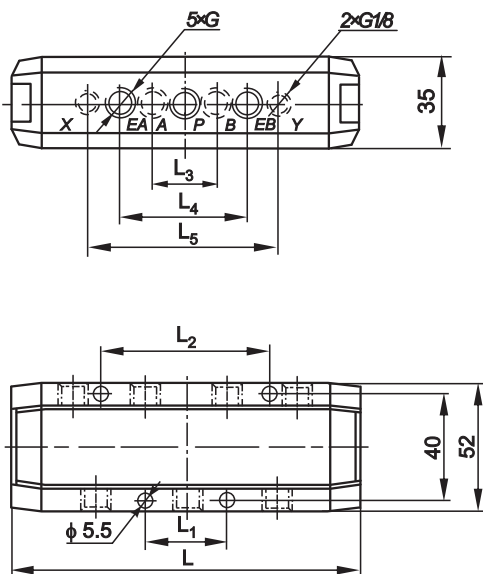

G	L	L <sub>1</sub>	L <sub>2</sub>	L <sub>3</sub>	L <sub>4</sub>	L <sub>5</sub>
G1/8	139	22	44	22	44	65
G1/4	164	32	62	32	64	90

ZASILANY PŁYTKOWO

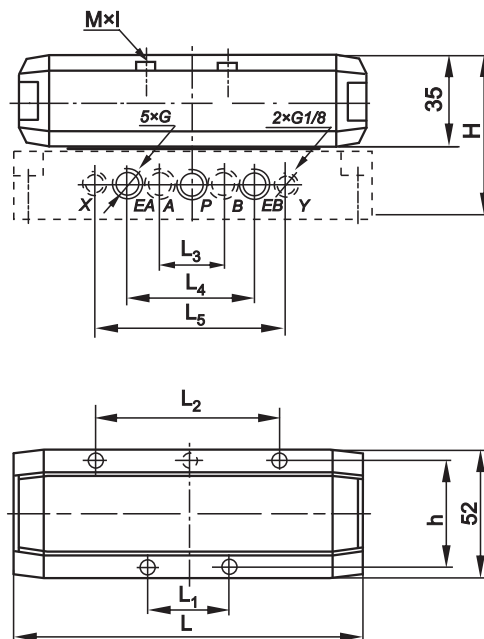

G	H	L	L <sub>1</sub>	L <sub>2</sub>	L <sub>3</sub>	L <sub>4</sub>	L <sub>5</sub>	h	M × I
G1/8-G1/4	59	139	34	60	26	56	82	40	M5×40-4szt
G1/4-G3/8	65	164	48	86	35	70	112	42	M5×40-4szt
G1/2-G3/4	73	224	52	104	52	104	144	40	M6×40-5szt

ZAWÓR ROZDZIAJĄCY 3/2 - STEROWANY PNEUMATYCZNIE SYGNAŁEM NISKOCIŚNIENIOWYM

ZASILANY PRZEWODOWO

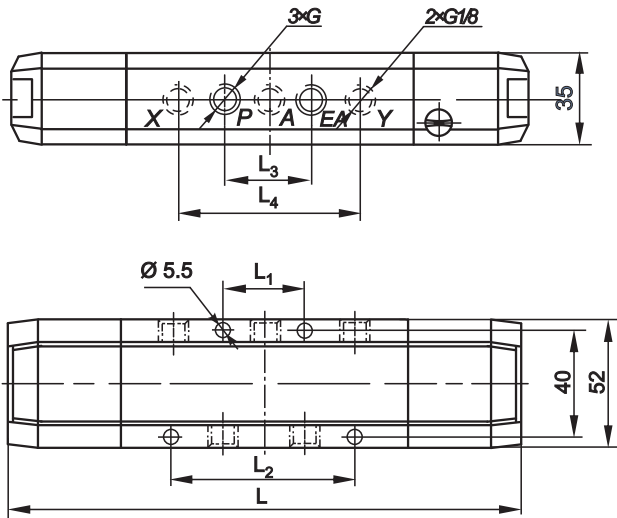

G	L	L <sub>1</sub>	L <sub>2</sub>	L <sub>3</sub>	L <sub>4</sub>
G1/8	193	26	48	22	43
G1/4	208	34	66	32	58

ZASILANY PŁYTKOWO

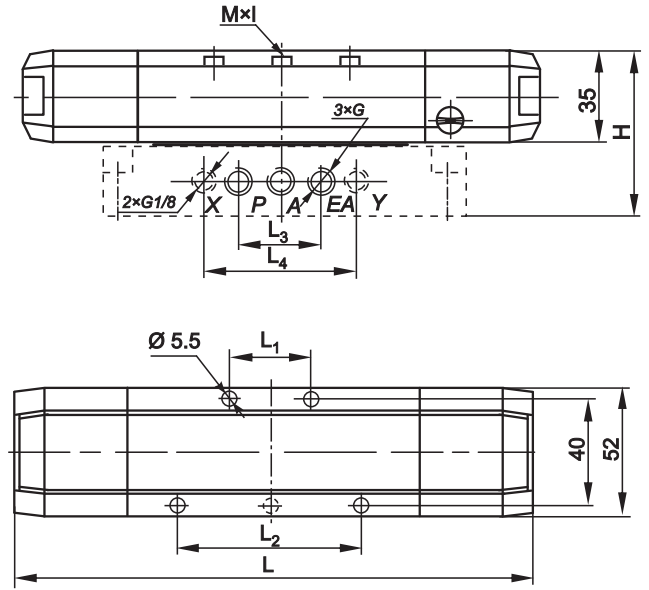

G	H	L	L <sub>1</sub>	L <sub>2</sub>	L <sub>3</sub>	L <sub>4</sub>	M × I
G1/4	59	193	26	48	26	52	M5×40-4szt
G3/8	64	203	34	66	35	66	M5×40-4szt
G1/2	69	243	39	81	48	88	M5×40-4szt
G3/4	74	268	52	92	52	104	M5×50-5szt

ZAWÓR ROZDZIAJĄCY 5/2 - STEROWANY PNEUMATYCZNIE SYGNAŁEM NISKOCIŚNIENIOWYM

ZASILANY PRZEWODOWO

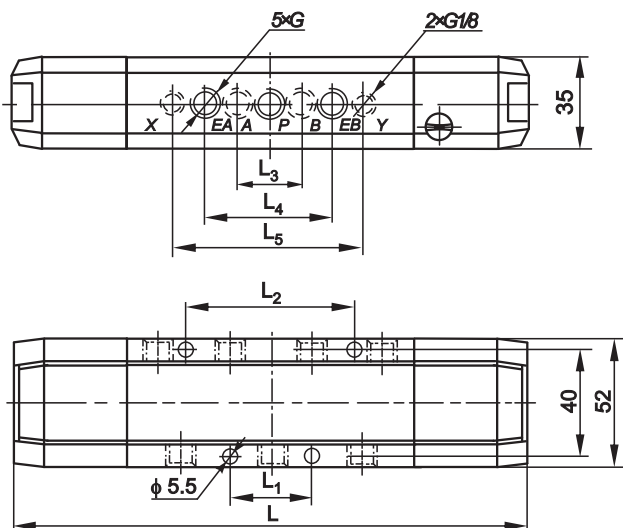

G	L	L <sub>1</sub>	L <sub>2</sub>	L <sub>3</sub>	L <sub>4</sub>	L <sub>5</sub>
G1/8	216	22	44	22	44	65
G1/4	240	32	62	32	64	90

ZASILANY PŁYTKOWO

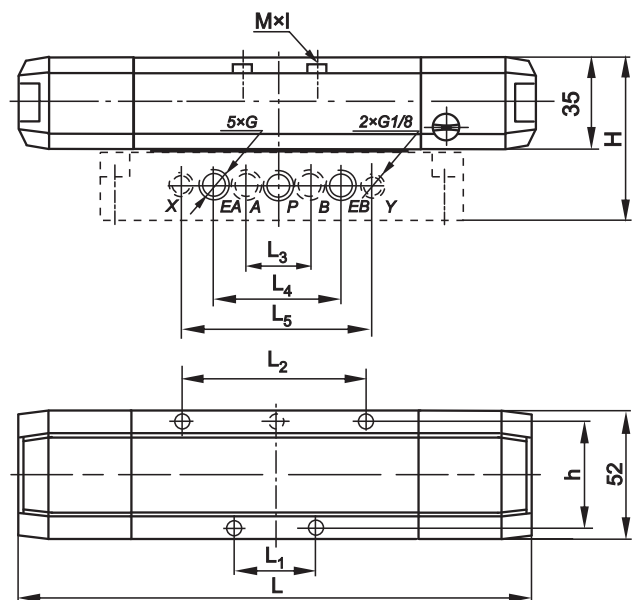

G	H	L	L <sub>1</sub>	L <sub>2</sub>	L <sub>3</sub>	L <sub>4</sub>	L <sub>5</sub>	h	M × I
G1/8-G1/4	59	215	34	60	26	56	82	40	M5×40-4szt
G1/4-G3/8	65	240	48	86	35	70	112	42	M5×40-4szt
G1/2-G3/4	73	320	52	104	52	104	144	40	M6×40-5szt

**ZAWÓR ROZDZIELAJĄCY 3/2 - STEROWANY PNEUMATYCZNIE SYGNAŁEM NISKOCIŚNIENIOWYM POWRÓT SPRĘŻYNĄ**

**ZASILANY PRZEWODOWO**

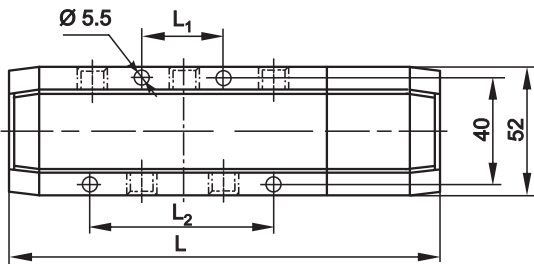
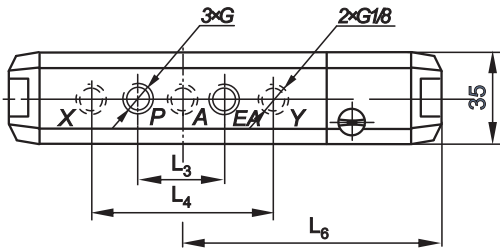

G	L	L <sub>1</sub>	L <sub>2</sub>	L <sub>3</sub>	L <sub>4</sub>	L <sub>6</sub>
G1/8	155	26	48	22	43	96
G1/4	170	34	66	32	58	104

**ZASILANY PŁYTKOWO**

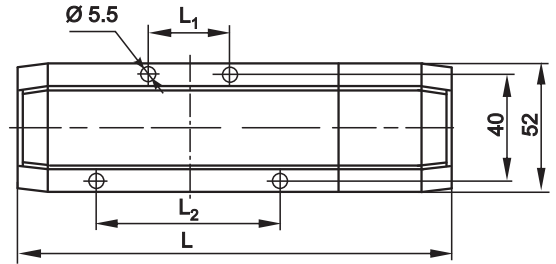
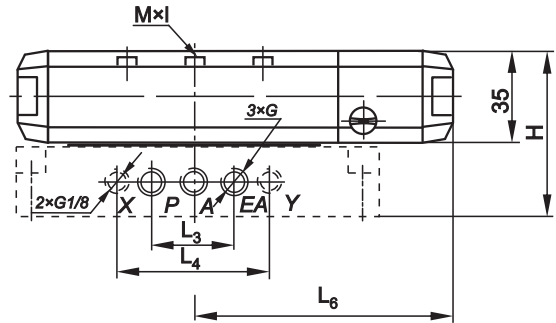

G	H	L	L <sub>1</sub>	L <sub>2</sub>	L <sub>3</sub>	L <sub>4</sub>	L <sub>6</sub>	M x I
G1/4	59	155	26	48	26	52	96	M5x40-4szt
G3/8	64	170	34	66	35	66	104	M5x40-4szt
G1/2	69	195	39	81	48	88	123	M5x40-4szt
G3/4	74	220	52	92	52	104	134	M5x50-5szt

**ZAWÓR ROZDZIELAJĄCY 5/2 - STEROWANY PNEUMATYCZNIE SYGNAŁEM NISKOCIŚNIENIOWYM POWRÓT SPRĘŻYNĄ**

**ZASILANY PRZEWODOWO**

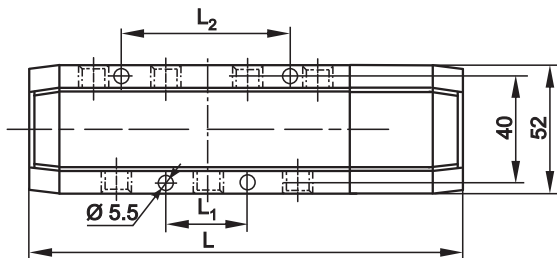
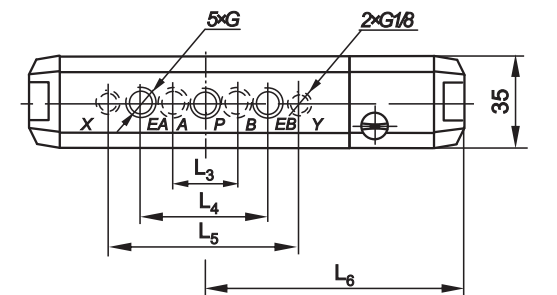

G	L	L <sub>1</sub>	L <sub>2</sub>	L <sub>3</sub>	L <sub>4</sub>	L <sub>5</sub>	L <sub>6</sub>
G1/8	177	22	44	22	44	65	107
G1/4	202	32	62	32	64	90	120

**ZASILANY PŁYTKOWO**

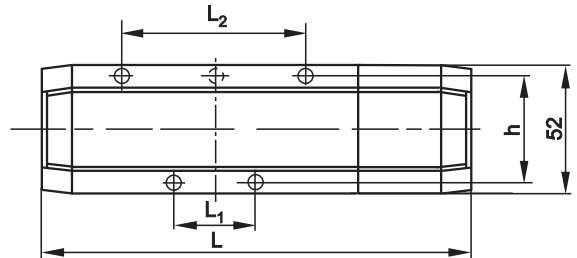
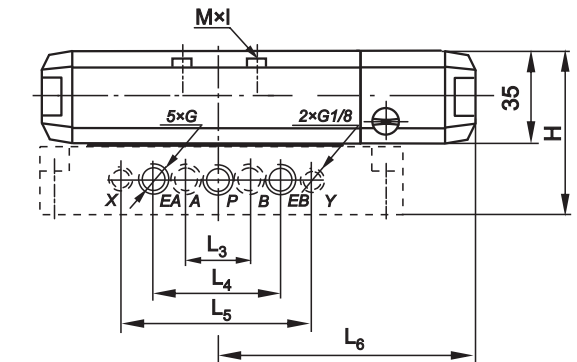

G	H	L	L <sub>1</sub>	L <sub>2</sub>	L <sub>3</sub>	L <sub>4</sub>	L <sub>5</sub>	L <sub>6</sub>	h	M x I
G1/8-G1/4	59	177	34	60	26	56	82	107	40	M5x40-4szt
G1/4-G3/8	65	202	48	86	35	70	112	120	42	M5x40-4szt
G1/2-G3/4	73	272	52	104	52	104	144	160	40	M6x40-5szt

ZAWÓR ROZDZIAJĄCY 3/2 - STEROWANY PNEUMATYCZNIE TŁOKIEM RÓŻNICOWYM

ZASILANY PRZEWODOWO

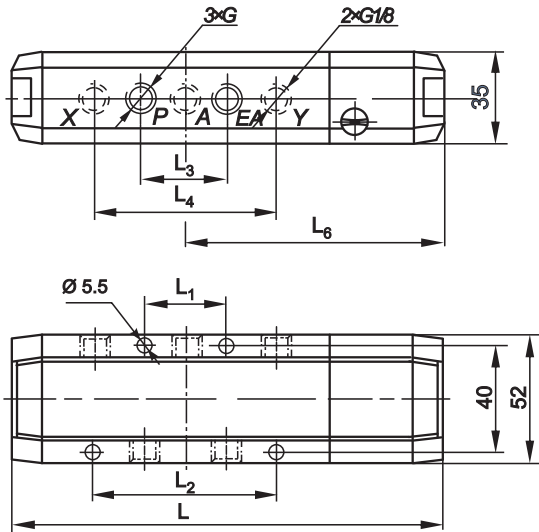

G	L	L <sub>1</sub>	L <sub>2</sub>	L <sub>3</sub>	L <sub>4</sub>	L <sub>6</sub>
G1/8	155	26	48	22	43	96
G1/4	170	34	66	32	58	104

ZASILANY PŁYTOWO

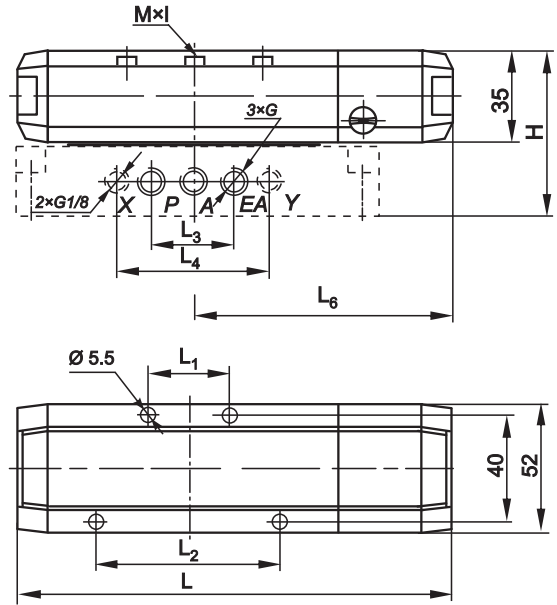

G	H	L	L <sub>1</sub>	L <sub>2</sub>	L <sub>3</sub>	L <sub>4</sub>	L <sub>6</sub>	M x I
G1/4	59	155	26	48	26	52	96	M5x40-4szt
G3/8	64	170	34	66	35	66	104	M5x40-4szt
G1/2	69	195	39	81	48	88	123	M5x40-4szt
G3/4	74	220	52	92	52	104	134	M5x50-5szt

ZAWÓR ROZDZIAJĄCY 5/2 - STEROWANY PNEUMATYCZNIE TŁOKIEM RÓŻNICOWYM

ZASILANY PRZEWODOWO

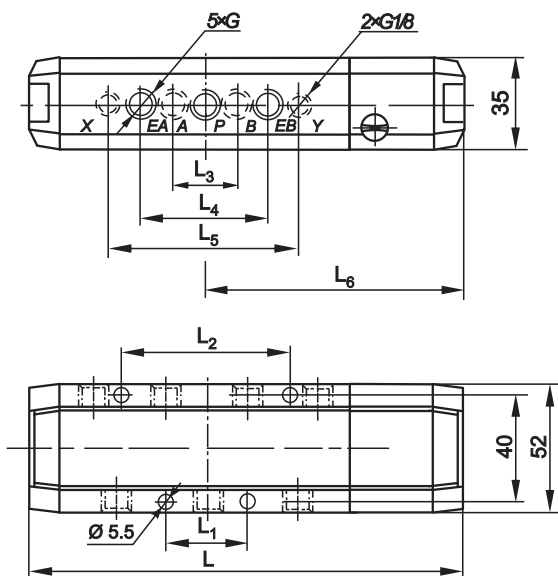

G	L	L <sub>1</sub>	L <sub>2</sub>	L <sub>3</sub>	L <sub>4</sub>	L <sub>5</sub>	L <sub>5</sub>
G1/8	216	22	44	22	44	65	107
G1/4	240	32	62	32	64	90	120

ZASILANY PŁYTOWO

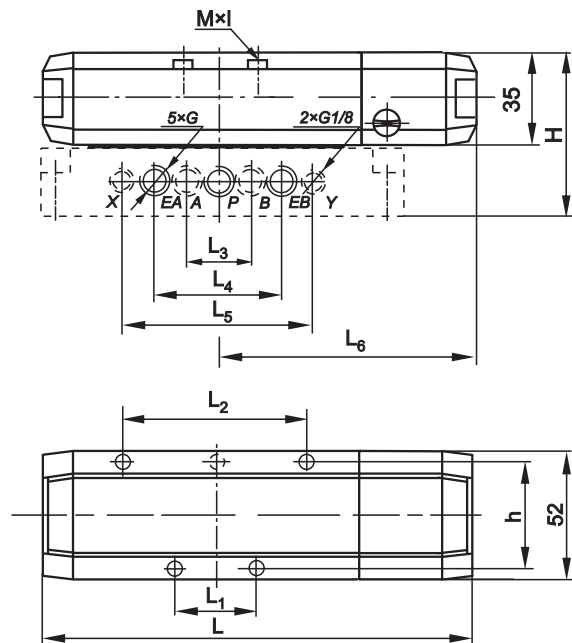

G	H	L	L <sub>1</sub>	L <sub>2</sub>	L <sub>3</sub>	L <sub>4</sub>	L <sub>5</sub>	L <sub>6</sub>	h	M x I
G1/8-G1/4	59	177	34	60	26	56	82	107	40	M5x40-4szt
G1/4-G3/8	65	202	48	86	35	70	112	120	42	M5x40-4szt
G1/2-G3/4	73	272	52	104	52	104	144	160	40	M6x40-5szt



ZAWÓR ROZDZIELAJĄCY 3/3 - STEROWANY PNEUMATYCZNIE

ZASILANY PRZEWODOWO

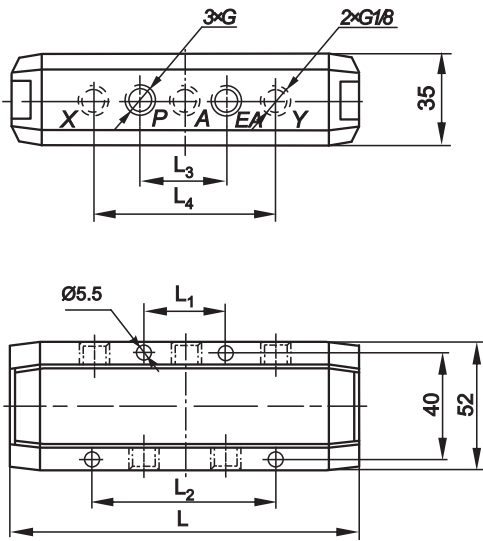

G	L	L <sub>1</sub>	L <sub>2</sub>	L <sub>3</sub>	L <sub>4</sub>
G1/8	117	26	48	22	43
G1/4	132	34	66	32	58

ZASILANY PŁYTOWO

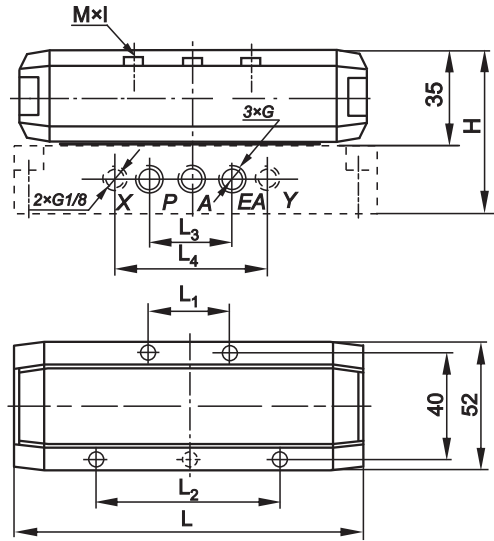

G	H	L	L <sub>1</sub>	L <sub>2</sub>	L <sub>3</sub>	L <sub>4</sub>	M × l
G1/4	59	117	26	48	26	52	M5×40-4szt
G3/8	64	132	34	66	35	66	M5×40-4szt
G1/2	69	147	39	81	48	88	M5×40-4szt
G3/4	74	172	52	92	52	104	M5×50-5szt

ZAWÓR ROZDZIELAJĄCY 5/3 - STEROWANY PNEUMATYCZNIE

ZASILANY PRZEWODOWO

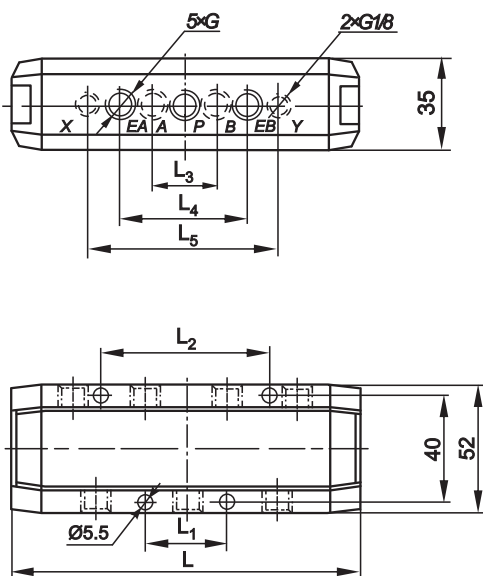

G	L	L <sub>1</sub>	L <sub>2</sub>	L <sub>3</sub>	L <sub>4</sub>	L <sub>5</sub>
G1/8	139	22	44	22	44	65
G1/4	164	32	62	32	64	90

ZASILANY PŁYTOWO

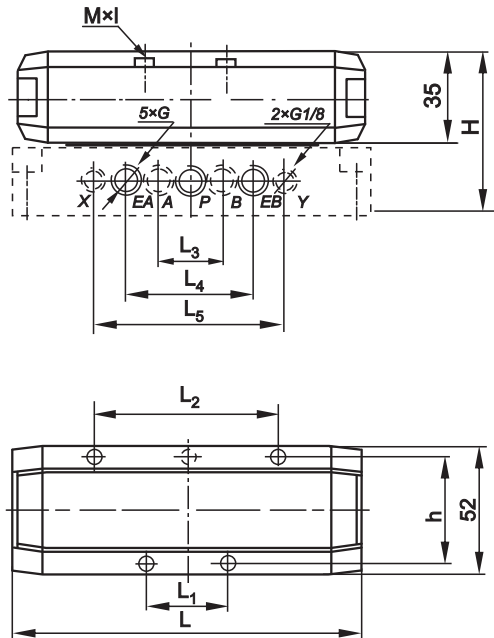

G	H	L	L <sub>1</sub>	L <sub>2</sub>	L <sub>3</sub>	L <sub>4</sub>	L <sub>5</sub>	h	M × l
G1/8-G1/4	59	139	34	60	26	56	82	40	M5×40-4szt
G1/4-G3/8	65	164	48	86	35	70	112	42	M5×40-4szt
G1/2-G3/4	73	224	52	104	52	104	144	40	M6×40-5szt