

Single point load cell up to 200 kg

with electrical output
for tension and compression forces



silicone free version with black pottant

Description

Single-point load cells are especially designed to be used in platform weighing. Without additional construction or compensation tasks they can be mounted directly under the platforms.

Basically it can be used in countless applications where high accuracy and easy mounting is required.

The load cell is easy to handle due to its simple force introduction. It has to be rectangular to the load cells axle.

Note

The load cells are to be mounted on an even surface.

The permitted load direction is marked with an arrow symbol.

Features

- for tension and compression forces
- high accuracy
- simple installation
- low installation height
- simple force introduction
- protection class IP 65

Measuring ranges

- 0.6 ... 200 kg

Applications

- apparatus construction
- laboratory-, letter- and analytic scales
- measuring - testing and controlling devices

Specific information

- Option: Silicon-free design

Model: F4221

Technical data

Model No.	F4221			Options
Nominal load F_{nom} [kg]	0.6, 1, 2, 3	5, 10, 15, 20, 30, 35, 50	60, 100, 200	silicone free
Platform dimensions [mm]	200 x 200	300 x 300	400 x 400	
Accuracy class	0.025%			
Limit load	150% F_{nom}			
Breaking load	> 200% F_{nom}			
Combined error	$\leq \pm 0.025\%$ of F.S.			
Max. dynamic load	$\pm 70\%$ F_{nom} acc. to DIN 50100			
Creep, 30 min. at F_{nom}	$\leq \pm 0.03\%$ of F.S.			
Zero return after 30 min. @ nominal load	0.03%			
Nominal deflection	< 1 mm			
Compensated temperature range	-10 ... +40°C			
Service temperature range	-20 ... +60°C			
Storage temperature range	-40 ... +70°C			
Reference temperature	23°C			
Temperature effect -span -zero	$\leq \pm 0.015\%$ of F.S. /10 K $\leq \pm 0.3\%$ of F.S. / 10 K			
Protection type (acc. to EN 60 529 / IEC 529)	IP 65			
Insulation resistance	> 5 G Ω / 50 V			
Analogue output				0(4)...20 mA; 0...10 VDC
- Output signal	2 mV/V			
- Bridge resistance	Input: 410 \pm 10 Ω Output: 350 \pm 3 Ω			
- Tolerance of span	$\leq \pm 10\%$ of F.S.			
- Zero	$\leq \pm 3\%$ of F.S.			
- Excitation voltage	10 V (max. 15 V)			
- Electrical connection	Cable, 4-wire			
Cable length	30 cm	40 cm	200 cm	Customized
Material of measuring device	Aluminum			

of F.S.= of full scale value

Dimensions

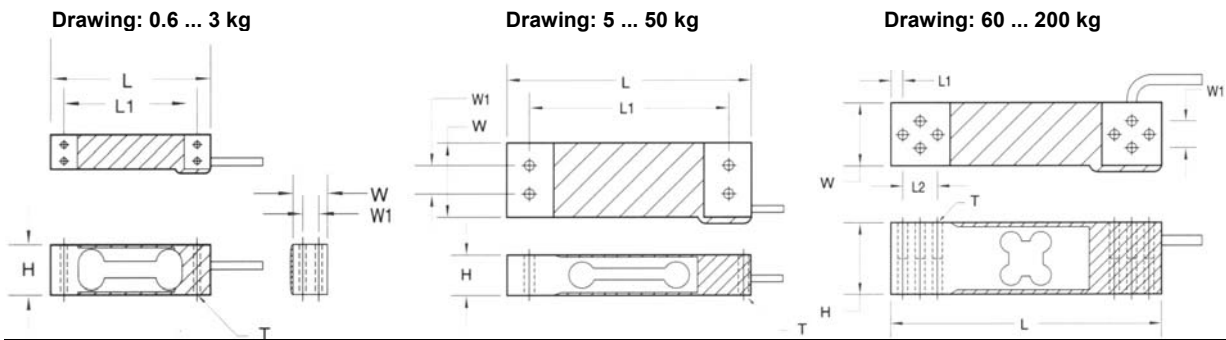

Nominal load [kg]	Dimensions [mm]							
	L	L1	L2	W	W1	H	T	connector cable
0.6 / 1 / 2 / 3	70	58	---	15	7	22	M3x0.5	0.3 m
5 / 6 / 10 / 15 / 20	130	106	---	30	15	22	M6x1.0	0.45 m
30 / 35 / 50	130	106	---	30	15	22	M6x1.0	0.45 m
60 / 100 / 200	150	7	19	35	15	40	M6x1.0	2 m

Electr. connection	≤ 50 kg	≥ 60 kg
Supply (-)	blue or black	black
Supply (+)	red	red
Sign. (+)	green	green
Sign. (-)	white	white

Subject to technical alternations