

Ring force transducer, universal

with electrical output
for tension and compression forces



Optional for SIL3-applications
with a 2-channel PC control



Description

These load cells are specially designed with small external dimensions. As a result of their compactness, these load cells can be used in a wide variety of industrial and laboratory applications.

Their compact dimensions make them particularly suitable for service in extremely constricted structures where tension and compression forces are to be measured.

Note

In order to avoid overloading, it is advantageous to connect the load cell electrically during installation and to monitor the measured value.

The force to be measured must be applied centrally and free of transverse force.

The load cells are to be mounted on a plane surface.

SIL-3 (Option)

In cooperation with the TÜV Süddeutschland a special security electronics has been developed for theatre and stage applications. It fulfils security standard SIL 3 with a 2-channel PC control in connection.

Features

- For tension or compression force measurements
- Compact small dimensions
- Simple installation
- Low installation height
- Protection class IP 66
- Accuracy 0.5% of full scale value

SIL-3 (Option)

- Security electronic
- SIL-3 approval with 2-channel PC control;
Certification: TÜV-Süd- No.
Z-IS-ATA3-MAN 6000219499
acc. to EN 62061:2005

Measuring ranges

- 5 kN ... 5000 kN

Applications

- Manufacturing plants
- Cutting tools
- Measurement and inspection equipment
- Test benches and production lines

SIL-3 (Option)

For theatre and stage design:

- Above-stage machinery
- Below-stage machinery
- Point hoists
- Bar hoists

Model: F6213

Technical data

Model	F6213	F62C3 SIL-3 (Option)
Nominal load F_{nom}	5, 10, 20, 50, 100, 200, 500, 1000, 2000, 3000, 5000 kN	
Accuracy class tension or compression	0.5% of F.S.	
Limit load	150% F_{nom}	
Breaking load	>300% F_{nom}	
Combined error	$\leq \pm 0.5\%$ of F.S.	
Max. dynamic load	$\pm 70\%$ F_{nom} acc. to DIN 50100	
Creep, 30 min. at F_{nom}	$\leq \pm 0.1\%$ of F.S.	
Nominal deflection	<0.1 mm	
Nominal temperature range	-10 ... +50°C	
Service temperature range	-30 ... +80°C	
Storage temperature range	-50 ... +95°C	
Reference temperature	23°C	
Temperature effect	-span -zero	$\leq \pm 0.1\%$ of F.S. / 10K $\leq \pm 0.1\%$ of F.S. / 10K
Protection type (acc. to EN 60529/IEC 529)	IP 66	
Noise emission	acc. to EN 61326	
Noise immunity	acc. to EN 61326	
Insulation resistance	> 2 G Ω	
Analogue output		
- Output signal	1 mV/V	4...16mA ; 3-wire signal swing 4mA \pm 0,2 mA, other on request
- Bridge resistance	350 Ω	
- Option	Cable integrated amplifier 0 (4) ... 20 mA, 0 ... 10 V DC	
- Excitation voltage	2 ... 12 V (max. 15 V)	10...30 VDC for current output SIL3-Relais 24VDC (+50%/-20%), power consumption ~ 100 mW
- Option	12...28 V DC for cable integrated amplifier	
- Electrical connection	Cable 3 m / 4-wire (up to 200 kN), Plug 6-pin from 500 kN incl. (Binder Serie 723)	4-wire (PUR) length: customer specific
Calibration control	- (Optional:100% signal)	
Mounting equipment	see sep. data sheet	
Material of measuring device	Stainless steel	
Certification		Certification: TÜV-Süd- No. Z-IS-ATA3-MAN 6000219499 acc. to EN 62061:2005
Weight (kN)		
- 5	0,13 kg	
- 10	0,15 kg	
- 20	0,17 kg	
- 50	0,18 kg	
- 100	0,46 kg	
- 200	0,73 kg	
- 500	1,5 kg	
- 1000	5,0 kg	
- 2000	8,94 kg	
- 3000	10,2 kg	
- 5000	31,0 kg	

of F.S. = full scale value

Dimensions

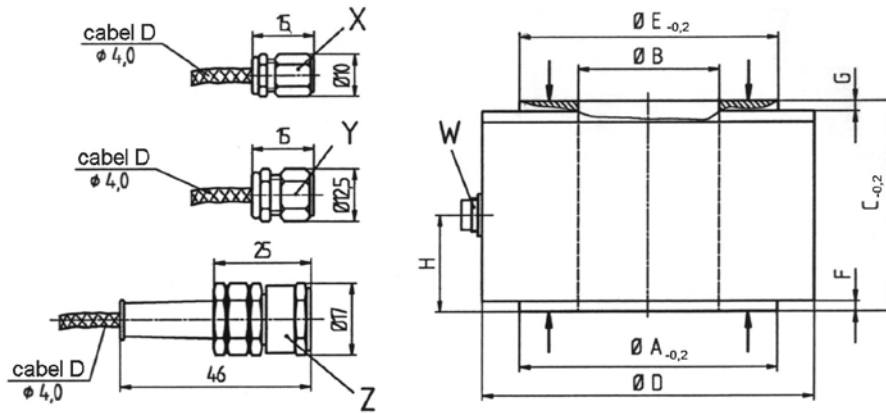

Measur. range [kN]	Dimensions in [mm]											
	ØA	ØB	C	ØD	ØE	F	G	H	W	X	Y	Z
5	10	5	30	30	10	2	2	15	---	•	---	---
10	14	8	30	30	14	2	2	15	---	---	•	---
20	22	15	30	40	22	2	2	15	---	---	•	---
50	28	15	30	40	28	2	2	15	---	---	•	---
100	35	20	40	55	35	2	2	20	---	---	---	•
200	47.5	25	40	64	47.5	2.5	2.5	20	---	---	---	•
500	60	30	50	80	60	4	3	26	•	---	---	---
1000	88	68	100	129	88	4	5	46.5	•	---	---	---
2000	105.6	68	100	160	106	5	5	46	•	---	---	---
3000	125	68	100	160	124.6	5	5	47	•	---	---	---
5000	220	100	120	270	220	5	5	60				

Electr. connection		
Vers. (-)	green	Pin 1
Vers. (+)	brown	Pin 2
Sign. (+)	yellow	Pin 4
Sign. (-)	white	Pin 5
Control	grey	Pin 6
Screen	Screen	Pin 3

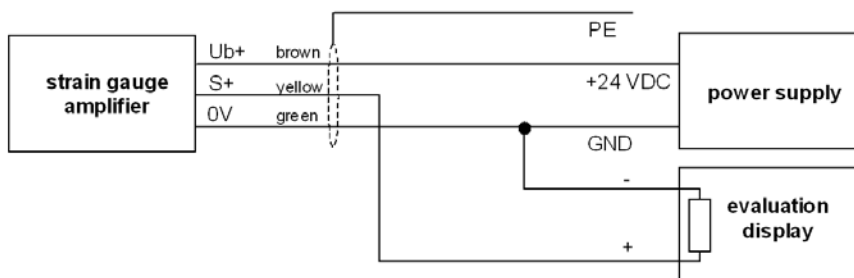

Pin assignment for cable integrated amplifier

Dimensions of optional cable amplifier, output signals 4...20 mA or 0...10V (with or without SIL-3) 3-wire.

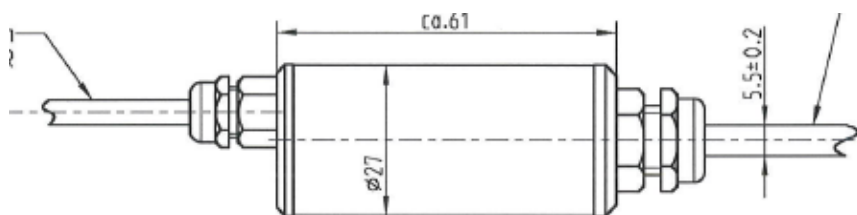

Electrical connection without amplifier (output signal 2mV/V; 4-wire)

Electical connection	
Supply: UB+	red
Supply: 0V	black
Signal: S+	white
Signal: S-	green

Analog output with cable amplifier (output signal 4...20mA or 0...10V) 3-wire

Electical connection	
Supply: UB+	brown
Supply: 0V	blue
Signal: S+	black
Signal: S-	blue
⊕	screen

Analog output with cable amplifier (output signal 4...20mA or 0...10V) and with SIL-3 (optional) 3-wire

Electical connection	
Supply: UB+	brown
Supply: 0V	blue
Supply Relay: UR	white
Supply Relay: 0V	blue
Signal: S+	black
Signal: S-	blue
⊕	screen

Brief description SIL-3

Amplifier-Electronics 4...20mA or 0...10V
for SIL-3 applications with 2-channel PC control
 (Certified by TÜV Süddeutschland, Germany)



Force Transducers, which are based on strain gauges, are working with four variable resistors (R1...R4) connected to a Wheatstone Bridge. Caused by deformation of the body the respective opposite resistors are lengthened or compressed in the same way. This results in an unbalanced bridge and a diagonal voltage U_0 .

This well proven design has been amended by an additional resistor R7 in order to monitor the condition of the amplifier unit and signal path. This resistor is connected as a shunt to resistor R5 by a relay contact (a) as soon as an excitation voltage U_r appears at relay A.

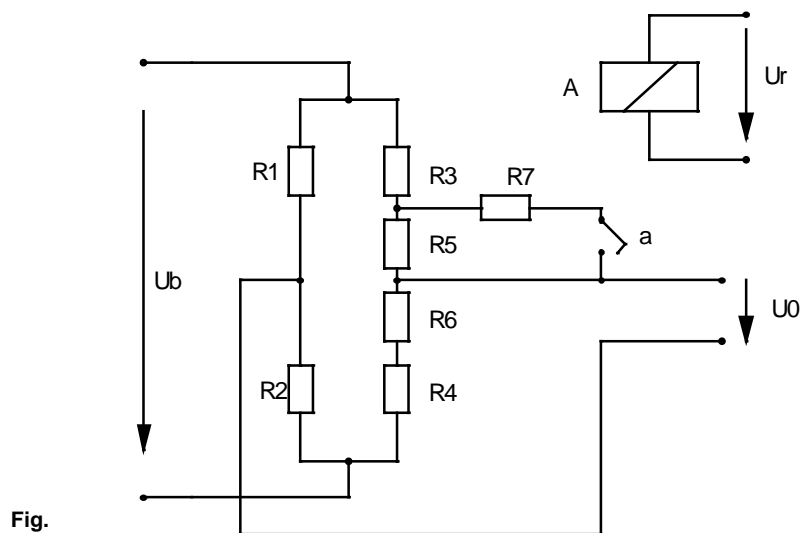
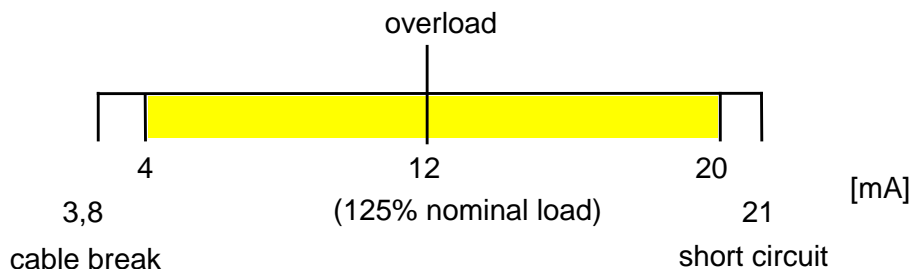

Fig.

The connection of resistor R7 will always result in a defined unbalancing of the zero point (diagonal voltage) of the Wheatstone Bridge.

An external independent control unit activates relay A which changes the output by a certain value. Because of security reasons the control unit has to be a 2-channel one. When the expected change of the output signal is detected it can be assumed that the whole signal path (Wheatstone Bridge – amplifier – output) works well. If it does not appear it can be concluded that there is a defect in the signal path.

The standard adjustment of force transducers with current output for overload control is e.g.:



With activating the check relay a fixed signal jump of 8 mA will exceed the overload limit in every working condition. The measurement's upper limit of 20 mA however will never be reached. This makes the checking of the signal jump possible.

Subject of technical changes