

Size	Voltage	Number of poles	Type	Airflow direction	ErP	Page	
250 mm	1~ 230 V	2	FN025-2E_WA_7	⇒ A ⇐ V	-	126	
		4	FN025-4E_W8_7	⇒ A ⇐ V	-	128	
300 mm	1~ 230 V	4	FN030-4E_WA_7	⇒ A ⇐ V	-	130	
			FN030-4E_WC_7	⇒ A ⇐ V	-	132	
310 mm	1~ 230 V	4	FN031-4E_WD_7	⇒ A ⇐ V	-	134	
			FN031-4E_0F.V7P2	⇐ V	-	136	
			FN031-4D_0F.V7P2	⇐ V	-	138	
350 mm	1~ 230 V	4	FN035-4E_WD_7	⇒ A ⇐ V	-	140	
			FN035-4E_WD_7	⇒ A ⇐ V	2013	142	
			FN035-4E_0F_7P2	⇒ A ⇐ V	2013 *	144	
		6	FN035-6E_0C_7P2	⇒ A ⇐ V	-	146	
			4-4	FN035-VD_0F_7P2	⇒ A ⇐ V	2015	148
400 mm	1~ 230 V	4	FN040-4E_0F_7P1	⇒ A ⇐ V	2015	150	
			FN040-4E_0F_7P2	⇒ A ⇐ V	2015	152	
			FN040-4E_2F_7P1	⇒ A ⇐ V	2013	154	
		6	FN040-6E_0F_7P1	⇒ A ⇐ V	-	156	
			4-4	FN040-VD_0F_7P1	⇒ A ⇐ V	2015	158
				FN040-VD_0F_7P2	⇒ A ⇐ V	2015	160
420 mm	1~ 230 V	4	FN042-4E_2F_7P1	⇒ A ⇐ V	2013	162	
		6	FN042-6E_0F_7P1	⇒ A ⇐ V	-	164	
		4-4	FN042-VD_2F_7P1	⇒ A ⇐ V	2015	166	
			6-6	FN042-SD_2C_7P1	⇒ A ⇐ V	-	168
450 mm	1~ 230 V	4	FN045-4E_4I_7P1	⇒ A ⇐ V	2013	170	
			FN045-4E_2F_7P2	⇒ A ⇐ V	2013	172	
			6	FN045-6E_2F_7P3	⇒ A ⇐ V	-	174
		6	FN045-6E_4F_7P1	⇒ A ⇐ V	2015 *	176	
			4-4	FN045-VD_2F_7P2	⇒ A ⇐ V	2015 *	178
				FN045-VD_4F_7P1	⇒ A ⇐ V	2015	180
			6-6	FN045-SD_2C_7P3	⇒ A ⇐ V	2013	182
FN045-SD_4F_7P1	⇒ A ⇐ V	2015		184			
500 mm	1~ 230 V	4	FN050-4E_4I_7P1	⇒ A ⇐ V	2013	186	
			6	FN050-6E_4F_7P1	⇒ A ⇐ V	2013	188
			8	FN050-8E_4C_7P1	⇒ A ⇐ V	-	190
		4-4	FN050-VD_4I_7P1	⇒ A ⇐ V	2015	192	
			6-6	FN050-SD_4F_7P1	⇒ A ⇐ V	2015	194
				8-8	FN050-AD_4C_7P1	⇒ A ⇐ V	-
560 mm	1~ 230 V	4	FN056-6E_4I_7P2	⇒ A ⇐ V	2013	198	
		4-4	FN056-VD_4M_7P2	⇒ A ⇐ V	2015	200	
		6-6	FN056-SD_4F_7P2	⇒ A ⇐ V	2015	202	
			8-8	FN056-AD_4F_7P2	⇒ A ⇐ V	2013	204

* with ZIEHL-ABEGG frequency inverter

Air flow q_v in m³/h

Type

0 5.000 10.000 15.000 20.000 25.000 30.000

Operating range
◆ Max. static pressure increase Δp_{sF} [Pa]

- FN025-2E_WA_7
- FN025-4E_W8_7
- FN030-4E_WA_7
- FN030-4E_WC_7
- FN031-4E_WD_7
- FN031-4E_0F.V7P2
- FN031-4D_0F.V7P2
- FN035-4E_WD_7
- FN035-4E_WD_7
- FN035-4E_0F_7P2
- FN035-6E_0C_7P2
- FN035-VD_0F_7P2
- FN040-4E_0F_7P1
- FN040-4E_0F_7P2
- FN040-4E_2F_7P1
- FN040-6E_0F_7P1
- FN040-VD_0F_7P1
- FN040-VD_0F_7P2
- FN042-4E_2F_7P1
- FN042-6E_0F_7P1
- FN042-VD_2F_7P1
- FN042-SD_2C_7P1
- FN045-4E_4I_7P1
- FN045-4E_2F_7P2
- FN045-6E_2F_7P3
- FN045-6E_4F_7P1
- FN045-VD_2F_7P2
- FN045-VD_4F_7P1
- FN045-SD_2C_7P3
- FN045-SD_4F_7P1
- FN050-4E_4I_7P1
- FN050-6E_4F_7P1
- FN050-8E_4C_7P1
- FN050-VD_4I_7P1
- FN050-SD_4F_7P1
- FN050-AD_4C_7P1
- FN056-6E_4I_7P2
- FN056-VD_4M_7P2
- FN056-SD_4F_7P2
- FN056-AD_4F_7P2

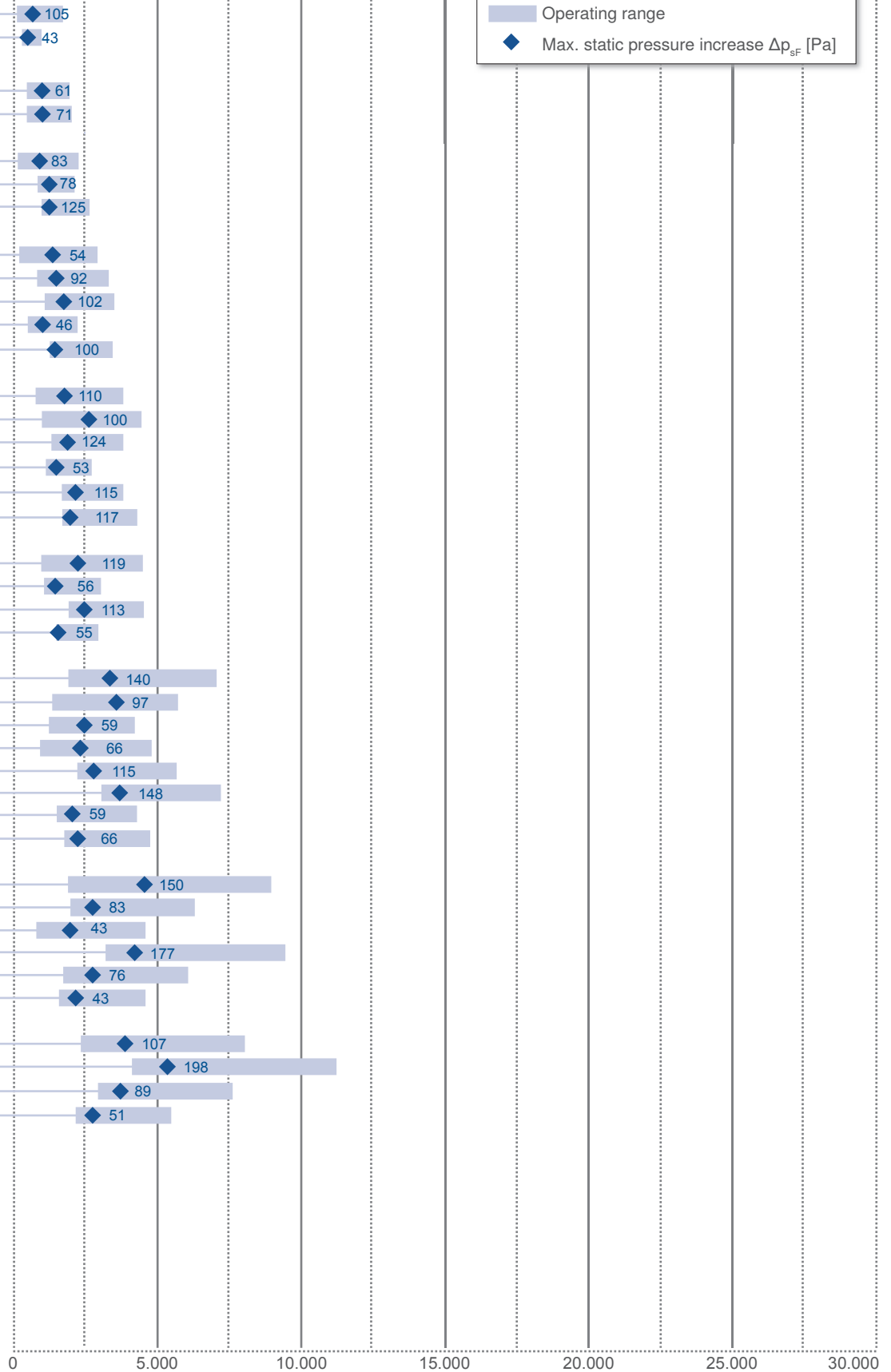

0 5.000 10.000 15.000 20.000 25.000 30.000

Air flow q_v in m³/h

Information

FE2owlet
ECblue

FE2owlet

FB

FC

System
components

Control
technology

Appendix

Size	Voltage	Number of poles	Type	Airflow direction	ErP	Page	
630 mm	1~ 230 V	6	FN063-6E_4I_7P1	⇒ - A - ⇐ - V	2013	206	
			FN063-6E_4M_7P1	⇒ - A - ⇐ - V	2013	208	
	3~ 400 V	8	FN063-8E_4I_7P1	⇒ - A - ⇐ - V	-	210	
			4-4	FN063-VD_6N.V7P4	⇐ - V	2013	212
			6-6	FN063-SD_4I_7P1	⇒ - A - ⇐ - V	2015	214
			8-8	FN063-AD_4I_7P1	⇒ - A - ⇐ - V	2013	216
			12-12	FN063-ND_4F_7P1	⇒ - A - ⇐ - V	-	218
710 mm	3~ 400 V	4-4	FN071-VD_6N_7P2	⇒ - A - ⇐ - V	2015	220	
			6-6	FN071-SD_6F_7P1	⇒ - A - ⇐ - V	2015	222
			8-8	FN071-SD_6K_7P1	⇒ - A - ⇐ - V	2015	224
			8-8	FN071-AD_6F_7P1	⇒ - A - ⇐ - V	2015	226
			12-12	FN071-ND_6F_7P1	⇒ - A - ⇐ - V	2015 *	228
800 mm	3~ 400 V	6-6	FN080-SD_6N.V7	⇐ - V	2015	230	
			FN080-SD_6N.V7P2	⇐ - V	2013	232	
		8-8	FN080-AD_6N.V7	⇐ - V	2015	234	
			FN080-AD_6N.V7P2	⇐ - V	2013	236	
			FN080-ND_6N.V7	⇐ - V	2013	238	
910 mm	3~ 400 V	4-4	FN091-VD_7Q_5P1	⇒ - A - ⇐ - V	2015	240	
			FN091-VD_7Q_5P1	⇒ - A - ⇐ - V	-	242	
		6-6	FN091-SD_6N_7P2	⇒ - A - ⇐ - V	2015	244	
			FN091-SD_7M_5P1	⇒ - A - ⇐ - V	2015	246	
			8-8	FN091-AD_6N_7P2	⇒ - A - ⇐ - V	2015	248
1000 mm	3~ 400 V	6-6	FN100-SD_7Q_5P1	⇒ - A - ⇐ - V	2015	250	
			FN100-SD_7Q_5P1	⇒ - A - ⇐ - V	2015	252	
		8-8	FN100-AD_7M_5P1	⇒ - A - ⇐ - V	2015	254	
			FN100-AD_7M_5P1	⇒ - A - ⇐ - V	2015	256	

* with ZIEHL-ABEGG frequency inverter

Air flow q_v in m^3/h

Type

0 5.000 10.000 15.000 20.000 25.000 30.000

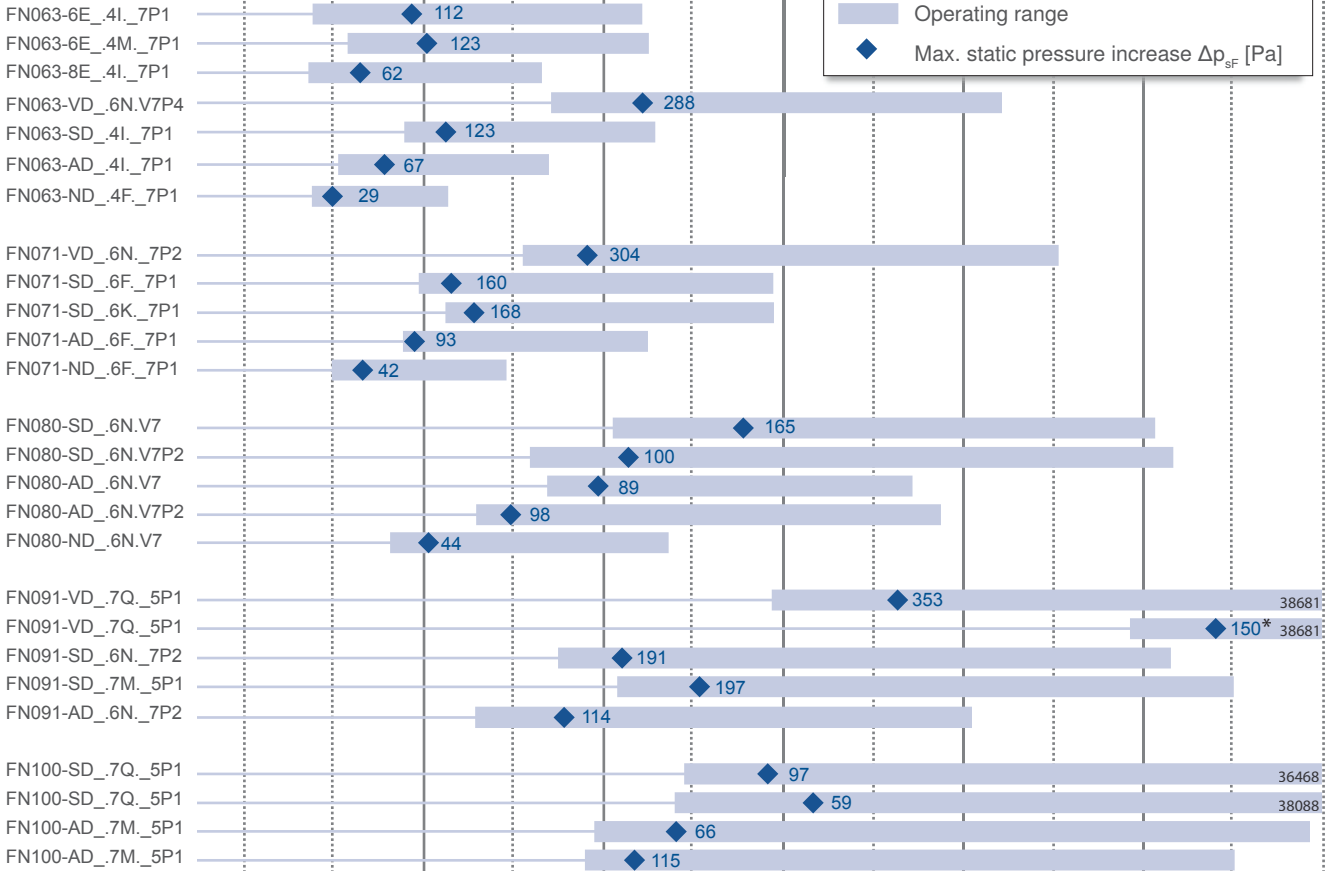

* max. $q_v = 31313$
max. $psF = 150$

0 5.000 10.000 15.000 20.000 25.000 30.000

Air flow q_v in m^3/h

Information

FE2owlet
ECblue

FE2owlet

FB

FC

System
components

Control
technology





Appendix

Performance data

Type	Characteristic curve	Voltage	Operating point	Current	Motor input power	Speed	Suction side sound power level
		U [V]		I [A]	P ₁ [W]	n [min ⁻¹]	
FN031-4E_WD_7	I	230	①	0.64	140	1250	
		230*	②	0.54*	120*	1330*	67
		230	③	0.44	100	1400	66
	II	170	④	0.62	100	860	
		170	⑤	0.56	95	1070	66
		170	⑥	0.44	75	1290	65
	III	135	⑦	0.52	70	580	
		135	⑧	0.50	70	720	59
		135	⑨	0.44	60	1050	62
	IV	110	⑩	0.42	46	450	
		110	⑪	0.42	46	520	56
		110	⑫	0.42	44	720	57

*rated data

Fan ordering information

Airflow direction A		Airflow direction V		
Design	D	L	H	I
				
Type	FN031-4ED.WD.A7	FN031-4EL.WD.A7	FN031-4EH.WD.V7	FN031-4EI.WD.V7
Article no.	161640	161641	161638	161637
Weight [kg]	4.30	5.80	5.80	4.30

Control technology

<p>Frequency inverter Fcontrol 1~</p>  <p>➤ Page 552</p>	<p>Motor protection units 1~</p>  <p>➤ Page 596</p>	<p>Transformer-based controllers 1~</p>  <p>➤ Page 587</p>	<p>Electronic voltage controllers 1~</p>  <p>➤ Page 562</p>
---	--	---	---

Airflow direction V

Design H - pipe sockets with a flange

Design I - axial bolted, mounting for bell mouth flange for pipe socket H or full bell mouth Q or L

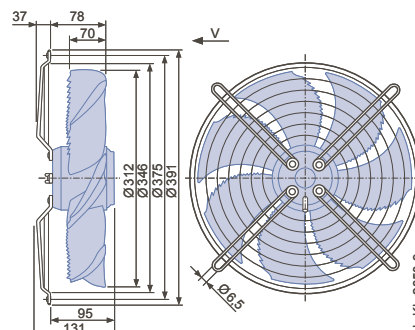
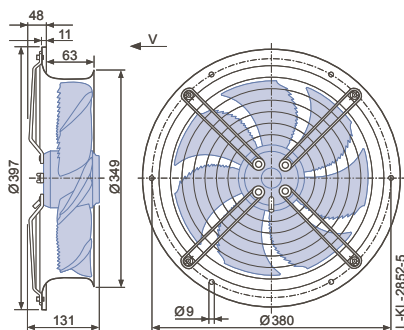

Information
FE2owlet ECblue
FE2owlet
FB
FC
System components
Control technology
Appendix

FE2owlet

for single phase alternating current, 4 pole

FNO31-4E



Description

Motor technology: AC
 Rated voltage U_N : 1~ 230 V \pm 10 %*
 Rated frequency f_N : 50 Hz* (60Hz data available)
 Motor input power P_1 : 0.12 kW*
 Rated current I_N : 0.62 A*
 Rated speed n_N : 1440 min⁻¹*
 Starting current I_s : 2.30 A
 Current increase ΔI : 35 %
 Service capacitor C_{400V} : 3.0 μ F
 Thermal class: **THCL155***
 Min. permitted conveyor temperature $t_{R(min)}$: -25 °C
 Max. permitted conveyor temperature $t_{R(max)}$: 70 °C
 Electrical connection: Terminal box
 Number of blades: 7
 Protection class: IP54
 Motor protection: Thermal contact
 Blades: High Performance Composite Material, uncoated, black
 Rotor: Aluminium, 1 coat paint, black
 Conformity: CE
ErP Data
 Is not subject to the ErP Guidelines ($P_1 < 125$ W)
 * Rated data

Characteristic curve

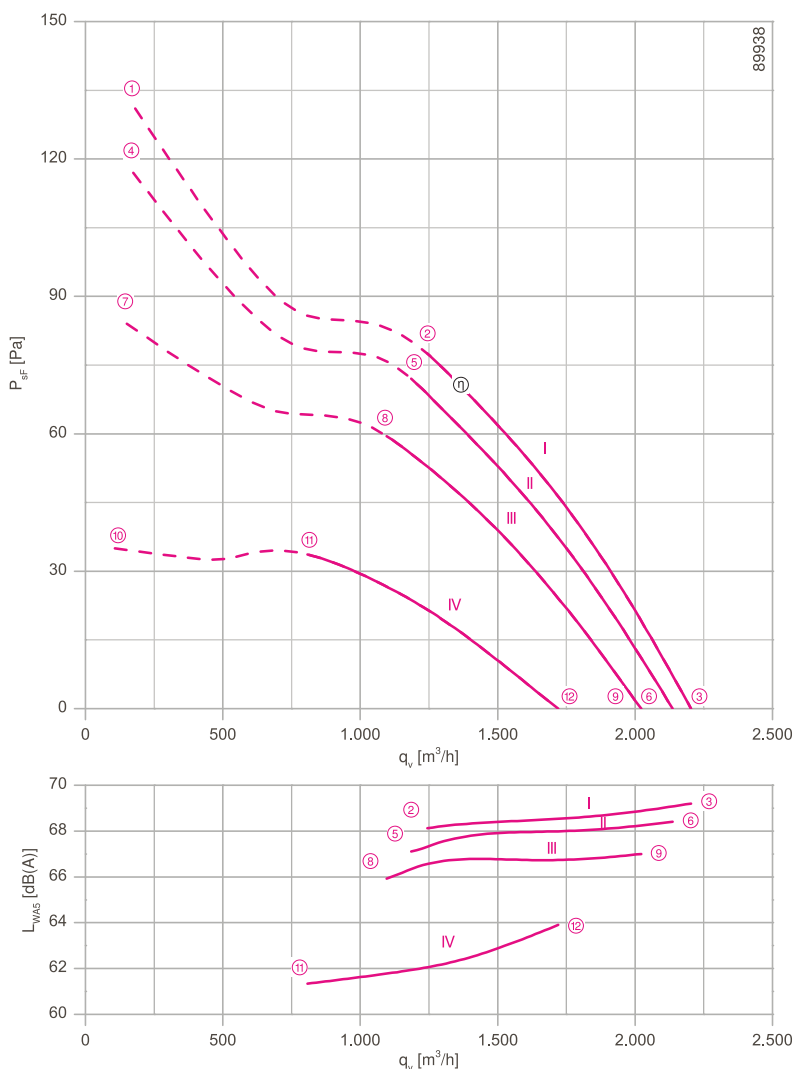

Measured in full bell mouth without guard grille in installation type A according to ISO 5801.

➤ Connection diagram 1360-104XA Page 608

➤ System components Page 524

Dimensions [mm]



Design K - axial bolted, mounted for short bell mouth E

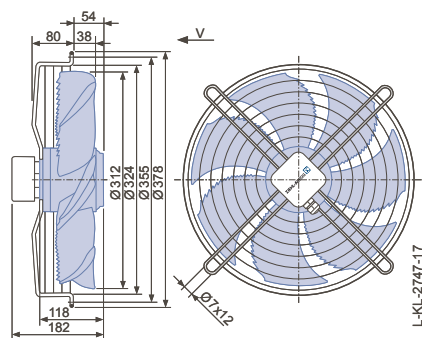

Performance data

Type	Characteristic curve	Voltage	Operating point	Current	Motor input power	Speed	Suction side sound power level
		U [V]		I [A]	P ₁ [W]	n [min ⁻¹]	
FN031-4E_0F_7P2	I	230	①	0.66	130	1430	
		230*	②	0.61*	120*	1440*	68
		230	③	0.58	110	1450	69
	II	170	④	0.68	110	1350	
		170	⑤	0.58	95	1390	67
		170	⑥	0.50	80	1410	68
	III	135	⑦	0.86	110	1150	
		135	⑧	0.70	90	1270	66
		135	⑨	0.58	75	1340	67
	IV	110	⑩	0.92	90	740	
		110	⑪	0.84	85	950	61
		110	⑫	0.72	75	1140	64

*rated data

Fan ordering information

← Airflow direction V

Design K



Type FN031-4EK.0F.V7P2
Article no. 159478

Weight [kg] 4.90

Control technology

<p>Frequency inverter Fcontrol 1~</p>  <p>➤ Page 552</p>	<p>Motor protection units 1~</p>  <p>➤ Page 596</p>	<p>Transformer-based controllers 1~</p>  <p>➤ Page 587</p>	<p>Electronic voltage controllers 1~</p>  <p>➤ Page 562</p>
---	--	---	--

FE2owlet

for three phase alternating current, 4 pole

FNO31-4D



Description

Motor technology: AC
 Rated voltage U_N : 3~ 230/400 V (Δ/Y) ± 10 %*
 Rated frequency f_N : 50 Hz* (60Hz data available)
 Motor input power P_1 : 0.12 kW*
 Rated current I_N : 0.68/0.39 A*
 Rated speed n_N : 1450 min⁻¹*
 Starting current I_A : 2.80 A / 1.70 A
 Current increase ΔI : 0 %
 Thermal class: THCL155*
 Min. permitted conveyor temperature $t_{R(min)}$: -40 °C
 Max. permitted conveyor temperature $t_{R(max)}$: 70 °C
 Electrical connection: Terminal box
 Number of blades: 7
 Protection class: IP54
 Motor protection: Thermal contact
 Blades: High Performance Composite Material, uncoated, black
 Rotor: Aluminium, 1 coat paint, black
 Conformity: CE

ErP Data

Is not subject to the ErP Guidelines ($P_1 < 125$ W)
 * Rated data

Characteristic curve

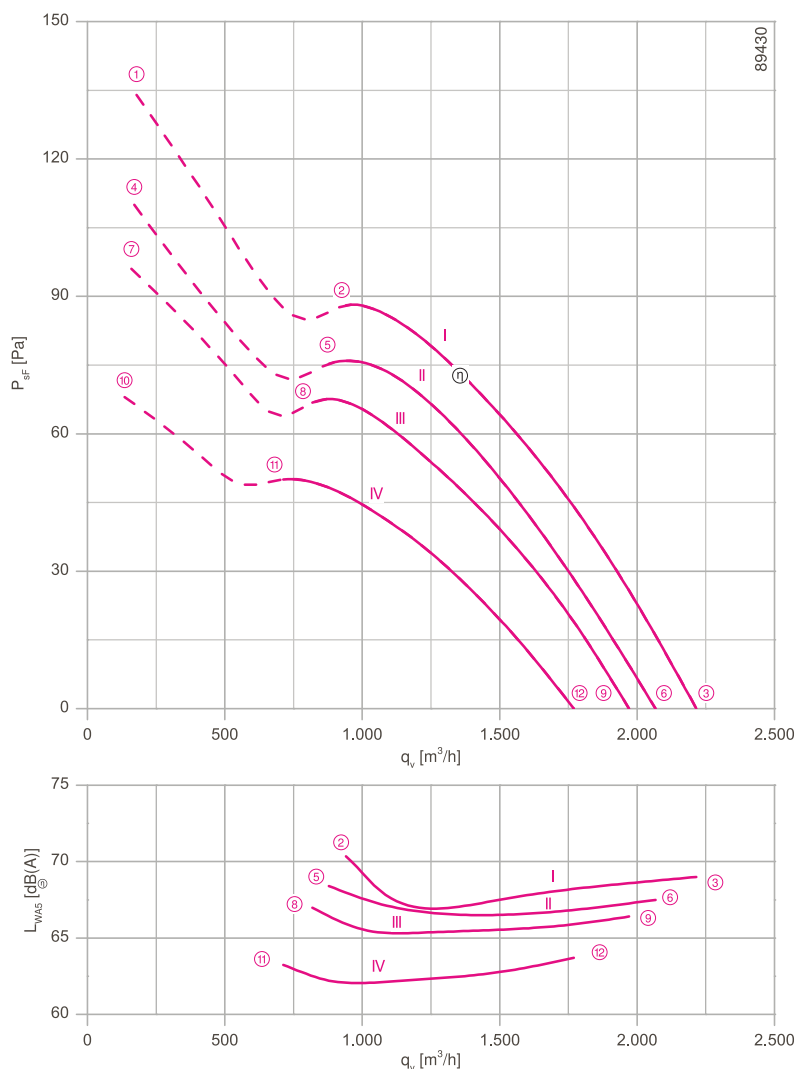

Measured in full bell mouth without guard grille in installation type A according to ISO 5801.

➤ Connection diagram 1360-106XA Page 608

➤ System components Page 524

Dimensions [mm]



Design K - axial bolted, mounted for short bell mouth E

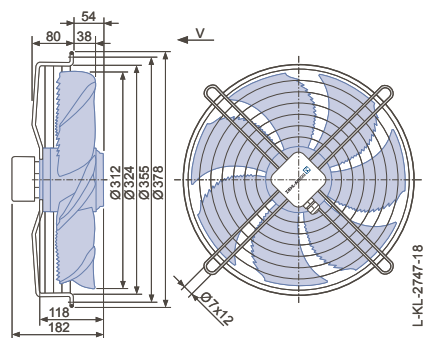

Performance data

Type	Characteristic curve	Voltage	Operating point	Current	Motor input power	Speed	Suction side sound power level
		U [V]		I [A]	P ₁ [W]	n [min ⁻¹]	L _{WAS} [dB]
FN031-4D_0F_7P2	I	400	①	0.40	140	1440	
		400*	②	0.39*	120*	1450*	70
		400	③	0.39	110	1460	69
	II	230	④	0.30	100	1310	
		230	⑤	0.28	90	1340	69
		230	⑥	0.25	75	1380	68
	III	190	⑦	0.32	90	1220	
		190	⑧	0.29	80	1260	67
		190	⑨	0.25	70	1320	66
	IV	145	⑩	0.33	75	1030	
		145	⑪	0.30	70	1090	63
		145	⑫	0.27	60	1180	64

*rated data

Fan ordering information

Airflow direction V

Design K



Type FN031-4DK.0F.V7P2
Article no. 159471

Weight [kg] 4.90

Control technology

<p>Frequency inverter Fcontrol 3~</p>  <p>➤ Page 558</p>	<p>Motor protection units 3~</p>  <p>➤ Page 596</p>	<p>Transformer-based controllers 3~</p>  <p>➤ Page 591</p>	<p>Electronic voltage controllers 3~</p>  <p>➤ Page 578</p>
---	--	---	--