



Hispec[®] HI2200/2300

HIGH TEMPERATURE PRESSURE TRANSDUCER



DESCRIPTION

HISPEC - HI2200/2300 series of high temperature pressure transducers with state-of-the-art Silicon-on-Sapphire sensor technology offer levels of accuracy and performance previously unobtainable or prohibitively expensive. It is capable of operating at constant 200°C both media and ambient.

The advanced sensor design consists of a piezoresistive silicon strain gauge circuit, which is epitaxially grown onto the surface of a sapphire diaphragm to form a single crystalline structure. The sapphire sensor element is then molecularly bonded to a titanium alloy sub-diaphragm. This enables the sensor to endure higher over-pressures and provides superb corrosion resistance. The completed sensor exhibits virtually no hysteresis and excellent long-term stability. With outstanding insulation properties, the sapphire substrate protects the strain gauge circuit and allows the sensor to operate over a very wide temperature range without loss of performance.

With pressure ranges from 0-1bar to 0-1500bar, the high temperature HISPEC transducer is available in two options; model HI2200 offers a non-compensated and un-rationalised signal output of between 10mV/V and 20mV/V, whilst model HI2300 is fully temperature compensated with a rationalised 10mV/V signal output. All models are available with either PTFE cable outlet or military bayonet style plug to MIL-C-26482, both of which are rated for use at 200°C. This means that not only does the transducer perform effectively at high media temperatures but uniquely can be used in environments where there are elevated ambient temperatures of up to 200°C. For instance this device may be mounted inside an oven or thermal chamber.

- SILICON-ON-SAPPHIRE SENSOR TECHNOLOGY
- PRESSURE RANGES 0-1bar TO 0-1500bar
- 10mV/V TYPICAL OUTPUT
- ACCURACY 0.1% NLHR
- HIGH OPERATING AMBIENT & MEDIA TEMPERATURE UP TO 200°C
- ALL TITANIUM ALLOY WETTED PARTS
- CABLE OUTLET OR MIL-C-26482 ELECTRICAL CONNECTOR



PRESSURE RANGES

0 to 1bar through to 1500 bar, see table below for list of all standard pressure ranges.

Range (bar)	Order Code	Range (bar)	Order Code
0-1	0001	0-60	0060
0-1.6	01.6	0-100	0100
0-2.5	02.5	0-160	0160
0-4	0004	0-250	0250
0-6	0006	0-400	0400
0-10	0010	0-600	0600
0-16	0016	0-700	0700
0-25	0025	0-1000	1000
0-40	0040	0-1500	1500

DIMENSIONS (in mm)

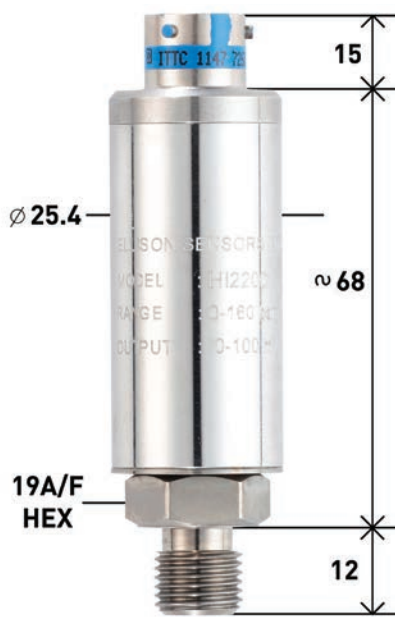

ELECTRICAL CONNECTION

MIL-C-26482

Pin	Designation
A	+supply
B	+output
C	-output
D	-supply
E	N/C
F	N/C

ELECTRICAL CONNECTION CABLE OUTLET

WIRE COLOUR	Designation
RED	+supply
GREEN	+output
YELLOW	-output
BLUE	-supply

ORDERING INFORMATION

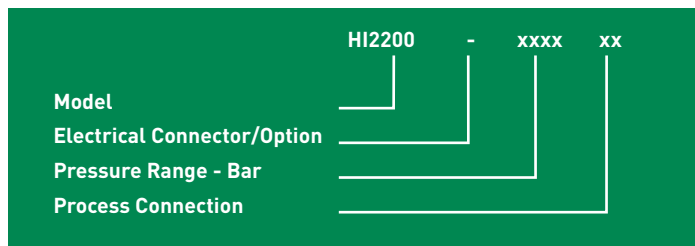

Output

10-20mV/V Un-rationalised and un-compensated
10mV/V Rationalised and compensated

Electrical Connection / Option

Cable Outlet 1m PTFE (models HI2200 & HI2300)
MIL-C-26482 6 pin bayonet (models HI2210 & HI2310)

Process Connection

1/4" BSP male thread
1/4" NPT male thread

EXAMPLE

Output Signal 10mV/V rationalised and compensated
MIL-C-26482 6 pin bayonet connector
Pressure range 0-25barg
Pressure connection 1/4" BSP male
Correct Part Number
For options not listed contact sales team

Model No.

H2200 or HI2210
H2300 or HI2310

Order Code

-

-

Order Code

AB
AM

Order Code

HI2310
-
0025
AB
HI2310-0025AB

SPECIFICATION

PRESSURE REFERENCE

Gauge

OVERPRESSURE

Pressure can exceed rated range by the multiple shown below with no damage or change in calibration above $\pm 0.5\%$ FS.

2x for ranges -1bar to 600bar
1.5x for 1000bar
1.1x for 1500bar

OUTPUT SIGNAL

HI22x0: un-rationalised mV output
Zero offset: $\pm 1\text{mV/Vdc}$,
Span tolerance: 10-20mV/V
HI23x0: 10mV/V (temperature compensated)
Zero offset: $\pm 1\text{mV}$
Span tolerance: $\pm 1\%$ FS

SUPPLY VOLTAGE

10Vdc nominal, 5-15Vdc

ACCURACY (NON LINEARITY, HYSTERESIS & REPEATABILITY)

$\pm 0.1\%$ FS Typical max. Best fit straight line.

PRESSURE MEDIA

All fluids compatible with titanium alloy.

OPERATING TEMPERATURE RANGE

Ambient: -40°C to $+200^\circ\text{C}$
Media: -50°C to $+200^\circ\text{C}$
Storage: $+5^\circ$ to $+40^\circ\text{C}$

TEMPERATURE EFFECTS

HI22x0 typical thermal zero and span coefficients compensated $\pm 0.05\%$ FS/ $^\circ\text{C}$.
HI23x0 $\pm 2.0\%$ FS TEb -40°C to $+150^\circ\text{C}$, typical thermal zero and span coefficients $\pm 0.005\%$ FS/ $^\circ\text{C}$.

INSULATION RESISTANCE

100Mohm @50Vdc all electrical connection to case

VIBRATION

30g peak, 10Hz -2KHz, 12mm double amplitude

MECHANICAL SHOCK

3x4ft drop on to concrete floor will not degrade performance

PRESSURE CONNECTION

1/4" BSP or 1/4" NPT Male (others on request)

ELECTRICAL CONNECTION

HI2x00: PTFE insulated flying lead, conductor size 7/0.16mm²
HI2x10: MIL-C-26482 high temperature 6 pin bayonet connector

DISCLAIMER : ESI Technology Ltd operates a policy of continuous product development. We reserve the right to change specification without prior notice. All products manufactured by ESI Technology Ltd are calibrated using precision calibration equipment with traceability to international standards.

