

Product Information

Level Sensor IL10



- Intrinsic safety ATEX applicable for Zone 0, 1, 2 also 20, 21 and 22
- Measuring ranges from 100 mbar..25 bar rel.
- Output 4..20 mA
- Process temperature -10..+60 °C
- Protection class IP68, max. immersion depth 300 m

Characteristics

The IL10 intrinsically safe level transmitter is designed for use in a wide variety of level measurement applications. The IL-10 has FM, ATEX and CSA approvals for installation in hazardous areas when used with the appropriate intrinsically safe zener barrier or isolating converter ST500Ex. Compensation for changes in barometric pressure is accomplished through a vent tube in the cable.

Technical data

Power supply	
Supply voltage	: 10..30 V DC (U+)
Medium temp.	: -10..+60 °C (compensated range 0..50 °C)
Ambient temp.	: -10..+60 °C
CE-conformity	: 2004/108/EG, EN61326 Emission (group 1 class B) and immunity (industrial locations)
Ex-directive	: ATEX94/9/EC, Data acc. to DMT 00 ATEX E 045X
Output	
Current	: 4..20 mA, 2-wire
Max. burden R _A	: ≤(U+ -10 V)÷0.02 A-(0.14Ω x cable length[m])
Accuracy	: 0.5 %
Material	
Process connection	: stainless steel [Hastelloy®]
Case	: stainless steel [Hastelloy®]
Membrane	: stainless steel [Hastelloy®]
Protection cap	: stainless steel [Hastelloy®]
Electrical connection	: PUR vented cable
Protection class	: IP68 (immersion depth up to 300 m)
Weight	: approx. 0.2 kg

Dimensions

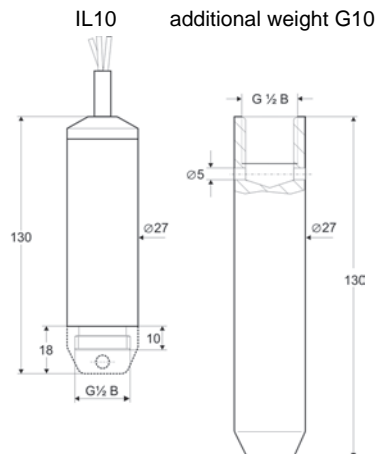

Connection diagram

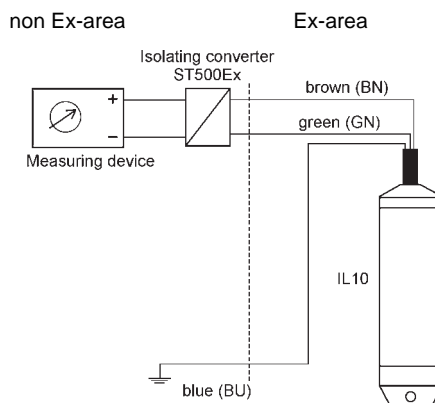

Ordering code

IL10 - 1. - 2. - 3.

1. Output	4..20 mA
2. Measuring range [bar]	0.1/ 0.16/ 0.25/ 0.4/ 0.6/ 1/ 1.6/ 2.5/ 4/ 6/ 10/ 16/ 25
3. Cable length [m]	Please insert
Accessories	
G10	additional weight 0.5 kg
ASK	anchor clamp steel zinc plate
ASK-E	anchor clamp stainless steel 1.4571
ASV-E	anchor gland stainless steel 1.4301

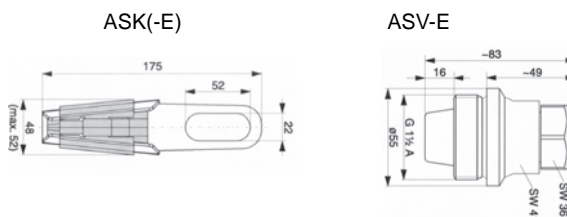

... professional Instruments "MADE IN GERMANY"