



S20-FSB-F-CC4-110A

The KSS is a heavy-duty solenoid controlled key driven electrical switch interlock ideal for the controlled isolation or switching of low current. This product is used where a process can send a signal to release a key, e.g. a robot has to finish a cycle prior to isolation. Upon removal of the key, the KSS switch contacts change to isolate the process. This type of isolator should be used for short term, off load isolation. The unit is ready for mounting into an existing panel or for surface mounting within its own IP65 rated lockable steel enclosure. The KSS is manufactured from either brass or stainless steel making it suitable for use in standard or harsh corrosive environments.

### Operation

The Castell KSS Solenoid Controlled Switch is typically used for machine isolation in applications where a machine has to finish a cycle prior to isolation.

#### KSS Solenoid Controlled Switch

- ① Key is trapped while power is on, solenoid is de-energised.
- ② An external signal is received and LED is illuminated. Push the button to energise the solenoid and remove the key.
- ③ Solenoid is energised, switch is locked out and key is free.



1. While the power is on and a machine is running, the key is trapped in the Solenoid Controlled Switch.
2. To release the key, an external signal must be received to energise the solenoid. With the solenoid energised, the LED will illuminate to confirm that the key can be removed ensuring the power is off.
3. The key can now be removed and taken to open the door lock and gain access to the machine area.

The KSS is available for different switching loads as KSS20 and KSS32 (20 amps power isolation respectively. See order information on page 7 for more details).

The KSS is available with different solenoid voltages as AC: 24, 110 or 240 V or DC: 12, 24, 110, 240 V (see order information on page 7 for more details).

The KSS comes with 4 or 6 contacts as standard with contacts arrangements as 2NO/2NC, 4NC or 3NO/3NC or 6NC.

The KSS is available as a back of panel mount (BOB) and as a surface mount version with an enclosure (FOB).

### Technical Data

Temperature rating	-25°C to +55°C
Type of mounting	Surface mount using suitable fasteners (see drawing on page 4-5 for hole details)
Weight	2kg
Material	Brass locks with powder coated mild steel enclosure
Power isolation	20A
Switch approvals	BS,UL,CSA & VDE or CCC
MTTF Certification	Available on request

### Application

A typical application of KSS solenoid controlled switch is machine guarding. It is usually used in combination with an access interlock such as the Salus for part body access or an access interlock with an exchange key for full body access control.

The KSS breaks the machine safety circuit, ensuring a machine is shut down. Once the machine has completed the cycle, an external signal is received by the solenoid, which is indicated by an illuminated LED. Activating the green button on the KSS will enable the key to be turned and removed ensuring the power is locked out. The key can then be taken to the AIE access interlock to enable access to the machine.

The machine cannot be restarted until the door is closed, the bolt is trapped in the AIE access interlock and the key is removed and taken to the KSS solenoid controlled switch.

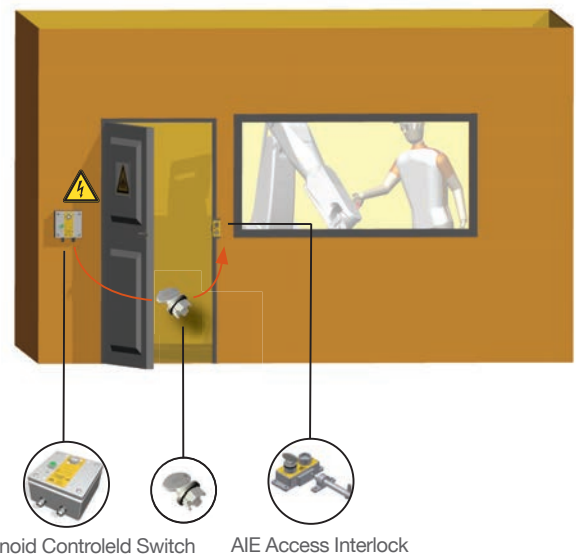

### EC-Declaration

We, the manufacturers, declare that the components, detailed herein and placed on the market, comply with all the essential health and safety requirements applying to them.

Empowered signatory:

Mr T.C. Whelan  
Managing Director



### Drawing

Dimensions:  
in mm

*Note: For safe mounting, use security screws*

KSS, panel mount (BOB: back of board)

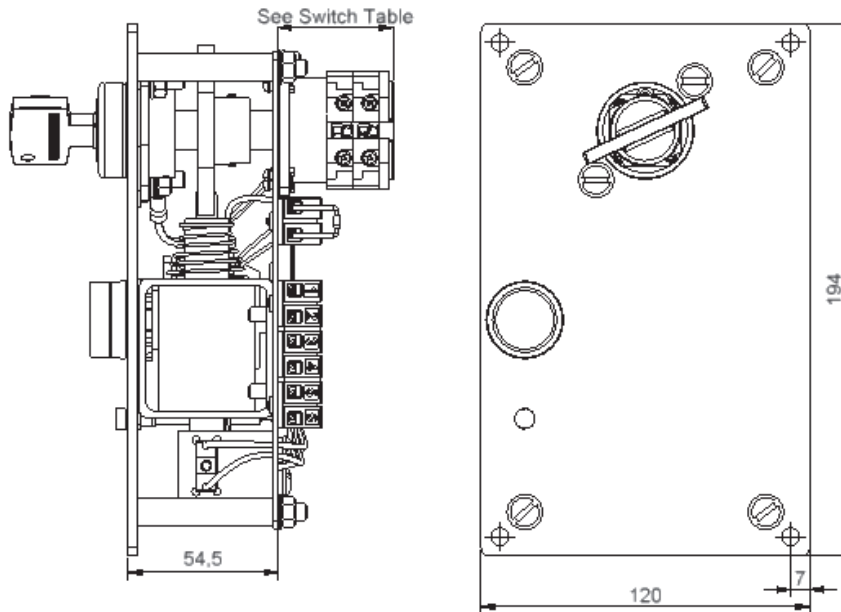

KSS, surface mounting (FOB: front of board)

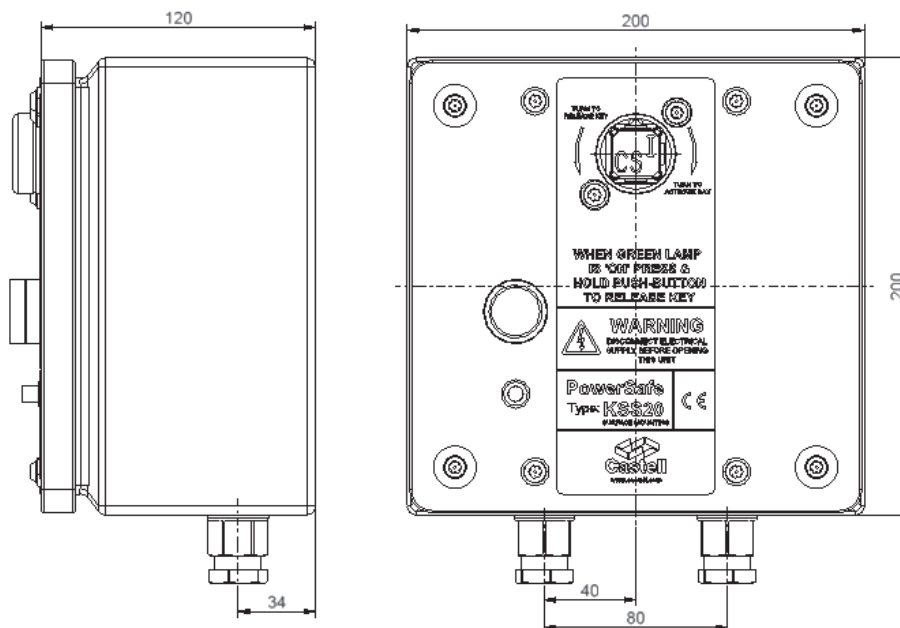

While every effort has been made to ensure the accuracy of the information provided, no liability can be taken for any errors or omission. Castell Safety International Limited reserves the right to alter specifications and introduce improvements without prior notice.

### Drawing

Dimensions:  
in mm

*Note: For safe mounting, use security screws*

KSS

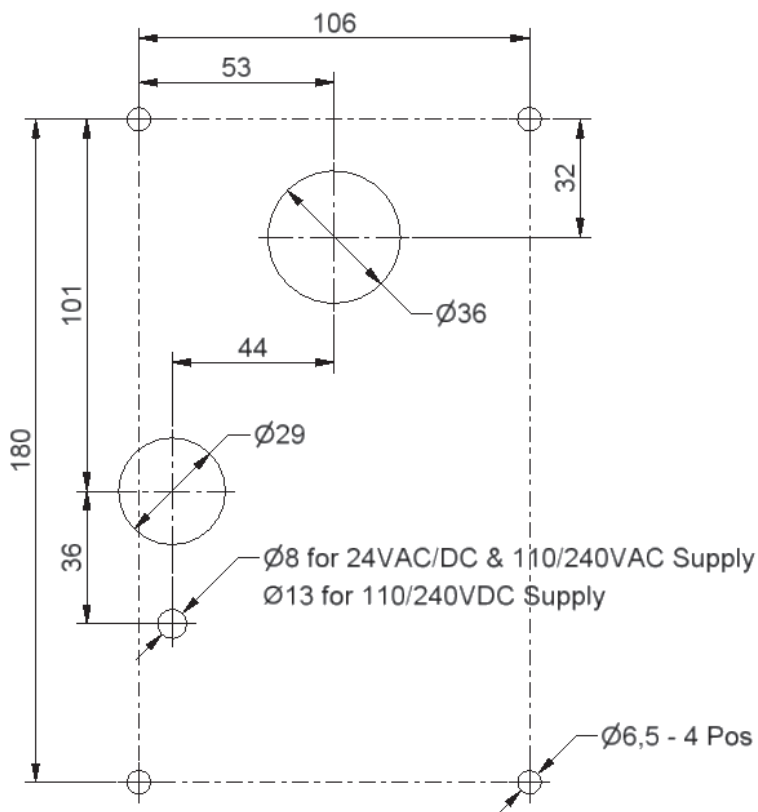

### Wiring Diagram

#### KSS, AC

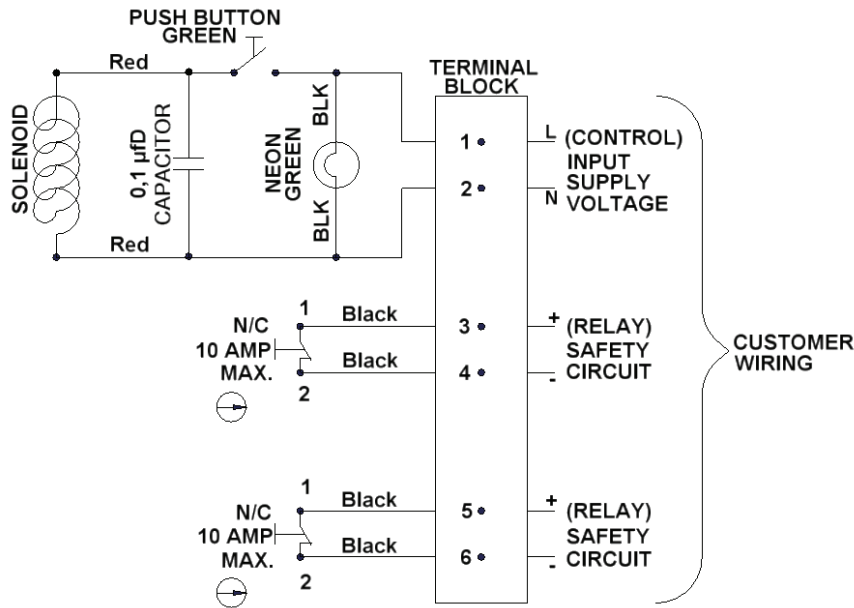

#### KSS, DC

