

MSR57P

Description

The MSR57P speed monitoring safety relay is designed to solve motion applications which require interaction by personnel during operation. It connects to any drive and monitors the speed using currently installed encoders. The MSR57P can be configured to unlock the access door only when the machine is either stopped or at a safe speed defined by the user. If required, the speed monitoring relay can monitor an enabling switch to constantly monitor personnel while in the hazardous area. Other supported functions are safe maximum speed and zero speed detection.

The MSR57P can be configured and monitored via two methods: drive explorer using a PC and the standard HIM device. During configuration, the user can set a variety of parameters to the specific requirements of their application including type of input devices, quantity, door locking and monitoring, enabling switches and a maintenance (safe speed) mode.

The MSR57P can easily be adapted to current installations with standard drives or drives with the safe-off feature. The safety relay uses standard outputs to control the drives speed but uses safety outputs to control the outputs of the drive. The speed is determined by using an encoder(s). This device can monitor the encoder data which is already transmitting to the drive, assuming an encoder is already installed, or a new encoder can be installed and only connected to the MSR57P. Two encoders are needed for Category 4, SIL 3 applications which cannot exclude shaft slippage and breakage.

This device also supports multiple axis applications. During configuration, it can be setup to be the first, middle or last axis in the chain. This is important since the input devices will all be installed on the first unit only while the output devices are connected to the last MSR57P in the chain.

Features

- SIL 3 IEC 61508
- Category 4 per EN 954-1
- Stop category 0, 1, 2
- Six N.O. solid-state safety outputs
- Four solid-state auxiliary outputs
- One or two encoders (sin/cos and TTL)
- Eight diagnostic LEDs
- DPI configuration port
- 67.5 mm DIN Rail housing
- Removable terminals

Specifications



Safety Ratings	
Standards	EN 954-1, ISO 13849-1, ISOTR 12100, IEC/EN 60204-1, ANSI B11.19, AS4024.1
Safety Classification	Cat. 4 per EN 954-1 (ISO 13849-1), SIL CL3 per EN IEC 62061, PLe per ISO 13849-1
Functional Safety Data * Note: For up-to-date information, visit http://www.ab.com/safety/	PFH _D : See website MTTF _d : See website Suitable for performance levels PLe (according to ISO 13849-1:2006) and for use in SIL3 systems (according to IEC 62061) depending on the architecture and application characteristics
Certifications	cULus, c-Tick, and TÜV
Power Supply	
Input Power Entry	24V DC, 0.8...1.1 x rated voltage PELV/SELV
Power Consumption	5 W
Inputs	
Safety Inputs	1 N.C. & 1 N.O., 2 N.C., 1 N.C., 2 OSSD
Input Simultaneity	Infinite or 3 sec (configurable)
Input Resistance, Max.	4 K Ω
Reset	Auto./Manual or Manual Monitored
Response Time	Configurable
Outputs	
Safety Contacts	6 N.O. Solid State
Auxiliary Contacts	4 N.O. solid state
Current, Max	Outputs 14, 24, 68, 78 24V DC, 2 A, shortlcircuit protected Outputs 34, 44 24V DC, 100 mA, shortlcircuit protected Outputs Y35, Y37 24V DC, 50 mA, shortlcircuit protected Door switches 51, 52 24V DC, 750 mA, shortlcircuit protected Outputs Y1, Y32, Y33 24V DC, 100 mA, shortlcircuit protected Pulse Outputs S11, S21 24V DC, 100 mA, shortlcircuit protected Pulse Inputs S12, S22, S32, S42, S52, S62, S72, S82, X32, X42, S34, Y2 8.5 mA per input
Environmental and Physical Characteristics	
Enclosure Type Rating/ Terminal Protection	IP40 (NEMA 1)/ IP20, DIN 0470
Operating Temperature [C (F)]	-5...+55 ° (23...131 °)
Vibration	10...55 Hz, 0.35 mm
Shock	10 g, 16 ms, 100 shocks
Mounting	35 mm DIN Rail
Weight [g (lb)]	335 (0.74)
Conductor Size, Max.	0.2...2.5 mm ² (24...12 AWG)

* Usable for ISO 13849-1:2006 and IEC 62061. Data is based on the following assumptions:
- Mission time/Proof test interval of 20 years
- Functional test at least once within six-month period

Product Selection

Inputs	Safety Outputs	Auxiliary Outputs	Terminals	Reset Type	Power Supply	Cat. No.
5 x 1 N.C., 2 N.C., LC, 1 N.O. + 1 N.C.	6 N.O. solid state	4 N.O. solid state	Removable	Auto./Manual or Manual Monitored	24V DC	440R-S845AER-NNL

Accessories

Description	Cat. No.
MSR57 Encoder cable with flying leads (2.5 meters)	1585J-M8RB-2M5
3 meter cable HIM	1202-C30
1 meter cable HIM	1202-C10
AnaCANda serial converter (RS232)	1203-SSS
AnaCANda USB converter	1203-USB
HIM full numeric LCD IP20 (NEMA 1)	20-HIM-A3
Kinetix 6000/7000 low profile connector kit	2090-K6CK-Dxxx
Kinetix 2000 low profile connector kit	2090-K2CK-D15M
HIM to MSR 57 cable (1 meter)	20-HIM-H10
Sin/Cos encoder (1024 PPR)	842HR-xJxxx15FWY2
TTL encoder (size 20)	845T-xxxxxxx
TTL encoder (size 25)	845H-SJxxx4xxYxx

Approximate Dimensions

Dimensions are shown in mm (in.). Dimensions are not intended to be used for installation purposes.

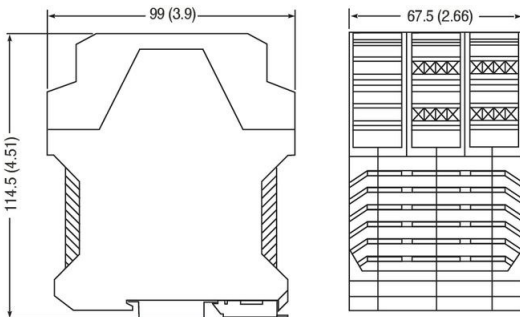

Block Diagram

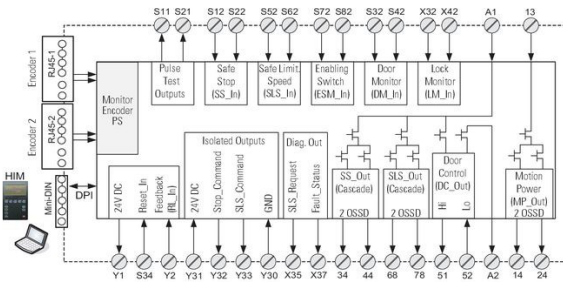

Typical Wiring Diagrams

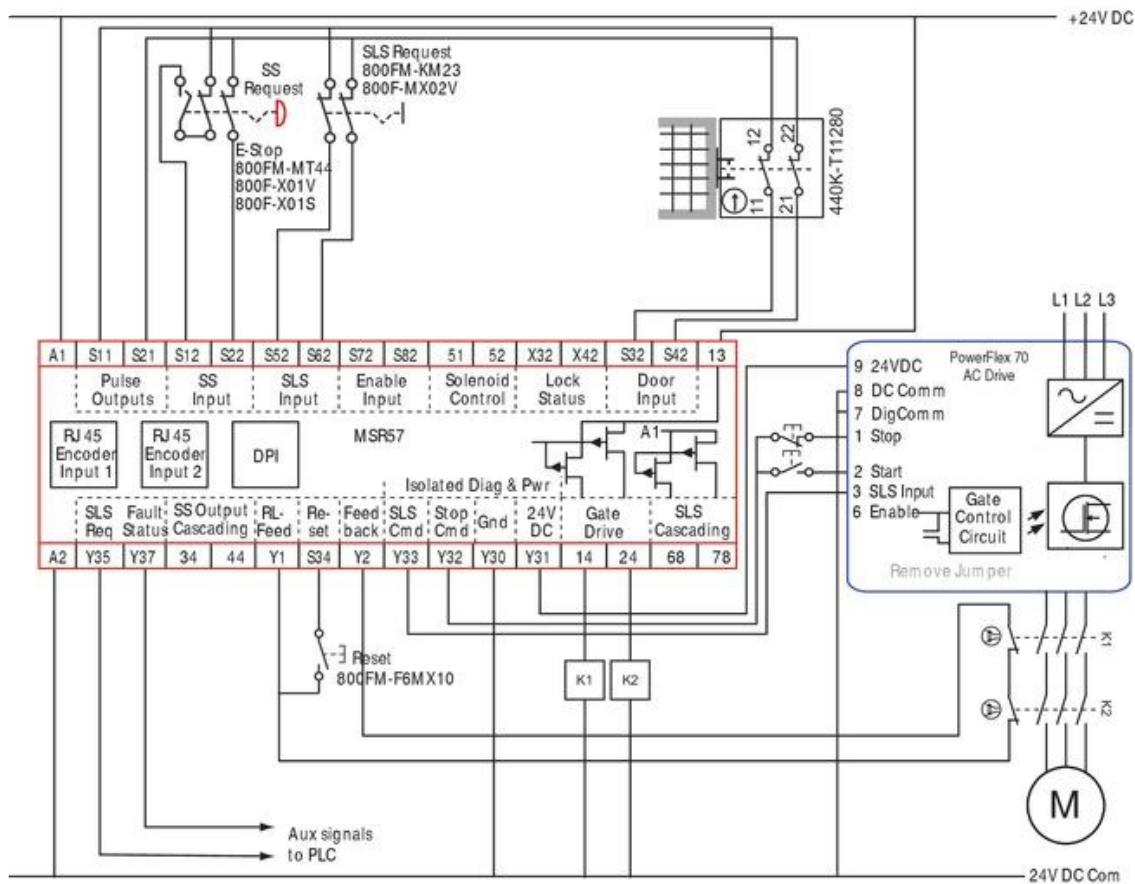

Note: Cat. 1 stop, 1 encoder, door monitoring, safe limited speed, PowerFlex 70 without safe off.

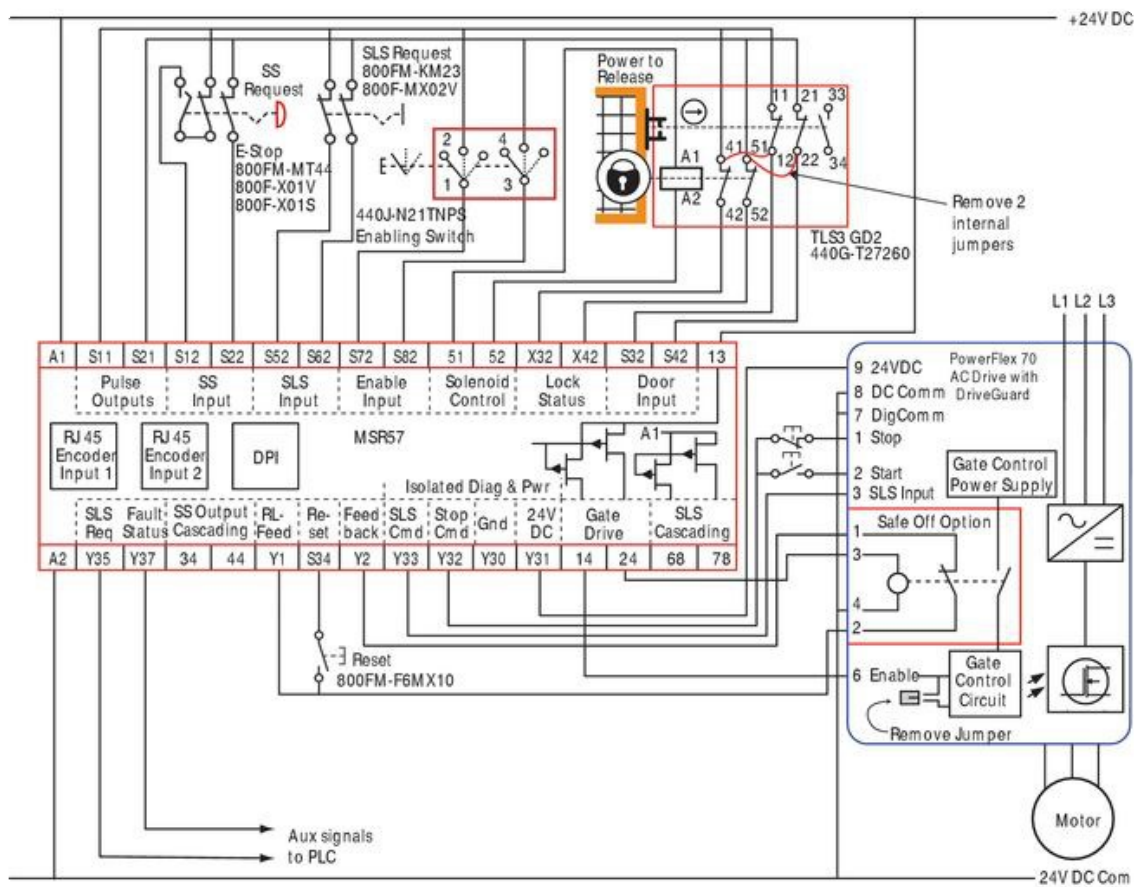

Note: Cat. 1 stop, 1 encoder, door monitoring, enabling switch, safe limited speed, PowerFlex 70 with safe off.

Application Details

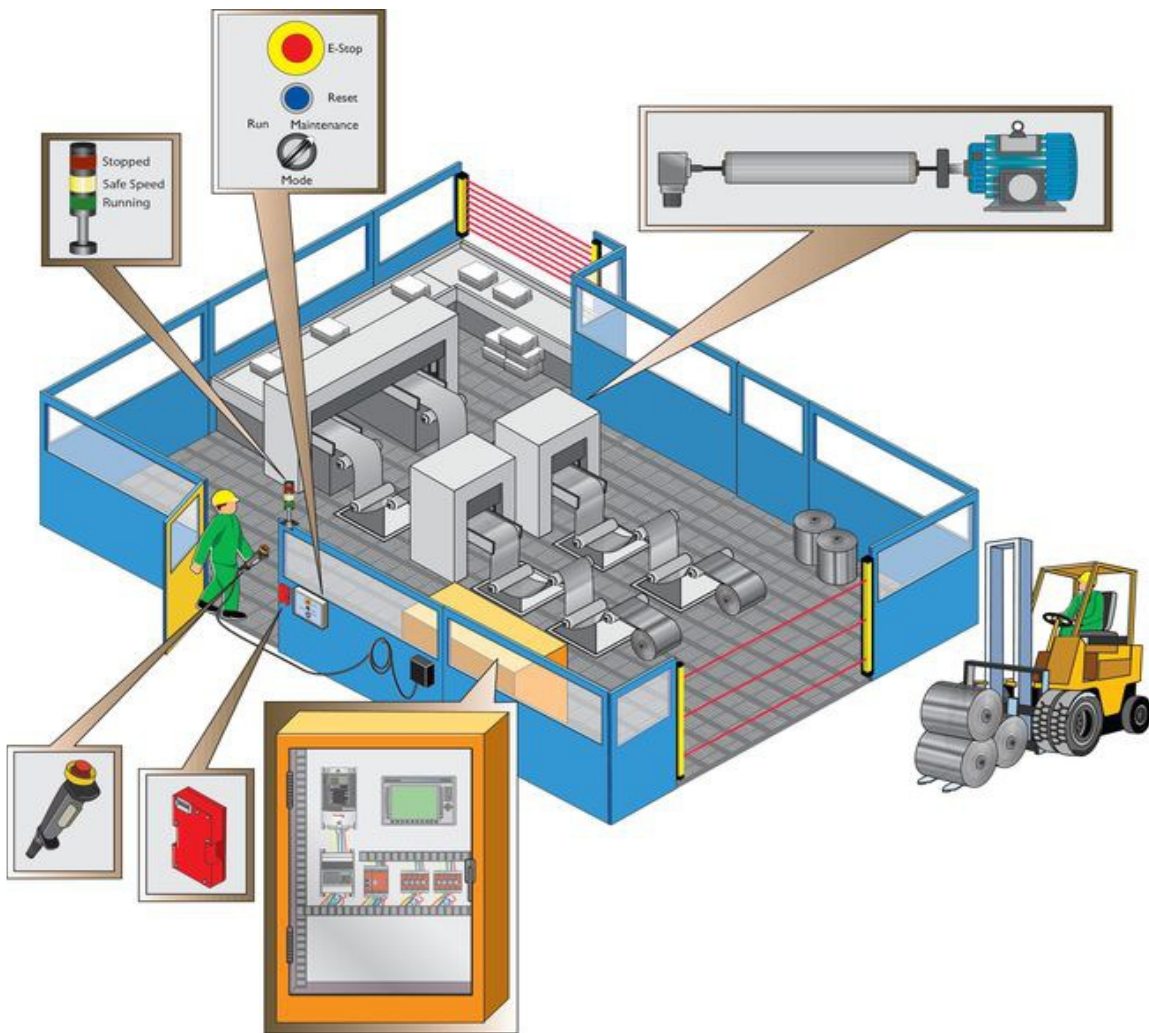

Operating Conditions

- The door is closed and locked with a TLS3 safety switch
- The machine is running at normal speed

Maintenance Conditions

- In order to remove a jam condition or during start-up personnel must enter the hazardous area.
- The operator moves Limited Speed Selector switch to "enable."
- The MSR57 monitors speed profile and verifies drive is reducing speed per the preconfigured profile.
- Once the speed is equal to or below limited speed value, the door is unlocked.
- If configured, user must hold enabling switch in the middle position before opening door. Otherwise the machine will shutdown.
- The operator performs maintenance on the machine.
- Once maintenance is complete, the operator exits machine, closes door and moves the safe limited speed switch to "maintenance" mode BEFORE releasing the enabling switch.
- The machine will resume normal speed according to the drive profile.

Remarks

- The MSR57 can also monitor if the speed has exceeded a preconfigured value and shutdown the process.
- The MSR57 is compatible with all drives and uses standard inputs on the drive to perform controlled start and stop sequences.
- Pressing the E-stop at any time, will cause the machine to stop according to the preconfigured stop mode.
- The MSR57 can also be used in cascading applications with multiple MSR57's and drives.