



# Protran® PR9000

PROCESS/INDUSTRIAL PRESSURE TRANSMITTER



## DESCRIPTION

The PR9000 Series pressure transmitters have been designed to meet the requirements of the majority of demanding industrial and process applications for pressure measurement requiring an output of 4-20mA. With robust stainless steel housing construction, this range of pressure transmitters incorporates the latest Silicon-on-Sapphire strain gauge technology, together with a custom design amplifier offering excellent stability and accuracy over a long service life.

The unique Silicon-on-Sapphire sensor technology provides outstanding performance and gives excellent stability over a wide temperature range. The advanced sensor design consists of a piezoresistive silicon strain gauge circuit, which is epitaxially grown onto the surface of a sapphire diaphragm to form a single crystalline structure. The sapphire sensor element is then molecularly bonded to a titanium alloy sub-diaphragm. This enables the sensor to endure higher over-pressures and provides superb corrosion resistance. The completed sensor exhibits virtually no hysteresis and excellent long-term stability. With outstanding insulation properties, the sapphire substrate allows the sensor to operate over a very wide temperature range without loss of performance.

An important feature of this transmitter is the easily accessible screw terminal connections and the zero/span potentiometers conveniently positioned inside the screw cover head for simplified on-site adjustment and installation. Cable entry to the transmitter head is through a PG9 gland or an optional M20 conduit fitting. Pressure connection is 1/2" BSP as standard, 1/2" BSPT, 1/2" NPT are also available together with hygienic and process flanges with media barriers. Pressure ranges are -1 to 0bar to 0-1500bar. Typical applications for this series of standard transmitters includes mechanical and civil engineering, process plant, production test facility, water resource, and power generation installations, and for any fluid or gas application requiring stable, repeatable and accurate pressure measurement.

An optional ATEX certified version of this product is available approved for explosion protection for flammable gases (zone 0), dusts (zone 20) and mining areas (group I MI).

- SILICON-ON-SAPPHIRE SENSOR TECHNOLOGY
- PRESSURE RANGES UP TO 1500bar
- 4-20mA OUTPUT
- ACCURACY 0.2% NLHR
- OPTIONAL ATEX APPROVED VERSION
- ALL STAINLESS STEEL HOUSING
- WETTED PARTS IN VARIOUS MATERIALS
- FULL RANGE OF BARRIER SEALS AND PROCESS FITTINGS
- ROBUST CONSTRUCTION



## PRESSURE RANGES

0 - 10bar through to 1500 bar, see table below for list of all standard pressure ranges.

Range (bar)	Order Code	Range (bar)	Order Code
0-1 Vac	V001	0-40	0040
0-0.1	00.1	0-60	0060
0-0.5	00.5	0-100	0100
0-1	0001	0-160	0160
0-1.6	01.6	0-250	0250
0-2.5	02.5	0-400	0400
0-4	0004	0-600	0600
0-10	0010	0-1000	1000
0-16	0016	0-1500	1500
0-25	0025		

## DIMENSIONS (in mm)

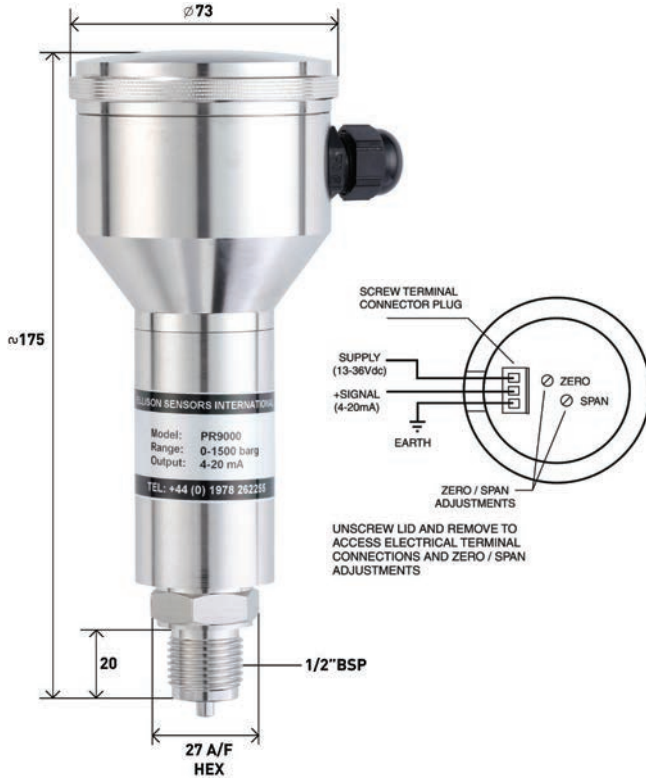

## ORDERING INFORMATION

Model	Electrical Connector	Pressure Range - Bar	Process Connection
PR9000	-	XXXX	XX

### ELECTRICAL CONNECTION/OPTION

- 4-20mA output with cable gland IP68
- 4-20mA output with M20 conduit connector
- ATEX certified with M20 conduit connector

### PROCESS CONNECTION

- 1/2" BSP male thread
- 1/2" NPT male thread

### EXAMPLE

- Output signal 4-20mA
- M20 conduit connector
- Pressure range 0-100barg
- Pressure connection 1/2" NPT male thread

### Correct Part Number

For options not listed contact sales team

### Order Code

-

A

EX

### Order Code

AC

AN

### Order Code

PR9000

A

0100

AN

PR9000A0100AN

## SPECIFICATION

### PRESSURE REFERENCE

Gauge

### OVERPRESSURE

Pressure can exceed rated range by the multiple shown below with no damage or change in calibration above  $\pm 0.5\%$ FS.  
 2x for ranges 1bar to 600bar  
 1.5x for 1000bar  
 1.1x for 1500bar

### OUTPUT SIGNAL

4-20 mA (2 wire configuration) as standard.

### ZERO OFFSET AND SPAN TOLERANCE

$\pm 0.08$ mA  
 $\pm 5\%$ FS adjustment with easy access trimming potentiometers.

### SUPPLY VOLTAGE

Measured across supply terminals on connector plug  
 13-36Vdc for 4-20mA versions  
 13-30Vdc for 0-5Vdc and 0-10Vdc versions

### PROTECTION OF SUPPLY VOLTAGE

Protected against supply voltage reversal up to 50Vdc

### ACCURACY (NON LINEARITY, HYSTERESIS & REPEATABILITY)

$\pm 0.20\%$ FS Typical Max. Best Fit Straight Line.

### PRESSURE MEDIA

All fluids compatible with titanium alloy diaphragm and 316 stainless steel wetted parts.

### OPERATING TEMPERATURE RANGE

Ambient/Media:  $-20^{\circ}$  to  $+85^{\circ}$ C  
 Storage:  $5^{\circ}$  to  $+40^{\circ}$ C

### TEMPERATURE EFFECTS

$\pm 1.5\%$ FS total error band for  $-20^{\circ}$  to  $+70^{\circ}$ C  
 Typical thermal zero and span coefficients  $\pm 0.02\%$ FS/ $^{\circ}$ C

### ATEX APPROVAL

Ex II 1 G Ex ia IIC T4 Ga (zone 0)  
 Ex II 1 D Ex ia IIIC T135°C Da (zone 20)  
 EX I M 1 Ex ia I Ma (group I M1)

### ATEX SAFETY VALUES

Ui = 28V  
 Ii = 119mA  
 Pi = 0.65W  
 Li = 0.1  
 Ci = 66Nf  
 Temperature range =  $-20^{\circ}$ C to  $+70^{\circ}$ C  
 Max. cable length = 85m

### ELECTROMAGNETIC CAPABILITY

Emissions: EN61000-6-4  
 Immunity: EN61000-6-2

### PRESSURE CONNECTION

1/2" BSP male (others on request)

### ELECTRICAL CONNECTION

Screw terminals for conductor sizes 0.2-2.0mm are located beneath the screw lid.  
 Cable entry to head is through an IP66 cable gland with compression seal for cable sizes 4-8mm. Optional M20 conduit fitting available.

**DISCLAIMER :** ESI Technology Ltd operates a policy of continuous product development. We reserve the right to change specification without prior notice. All products manufactured by ESI Technology Ltd are calibrated using precision calibration equipment with traceability to international standards.

