

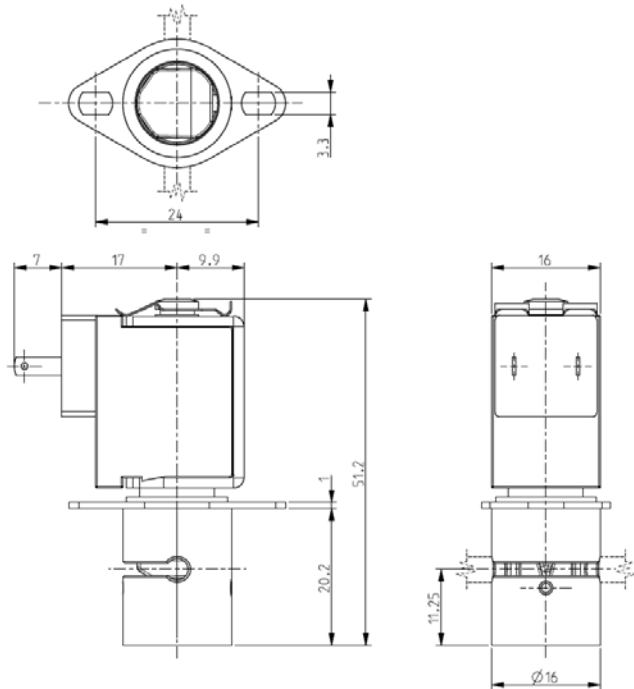

PINCH SOLENOID VALVE 2/2 – NC (Normally closed)

S104



► **GENERAL FEATURES**

Pinch solenoid valve, suitable to shut off media without producing neither turbulent flows, nor dead spaces.
 High flow rate under the same conditions of internal diameter of different solenoid valves; the system allows a bi-directional through flow.
 The valves are suitable for soft SILICONE tubings or others, similar as to elasticity and hardness (50 shore A).
 Silent model.
The tubing is the only material in contact with the fluid.
 The tubings are not included in our supply.

► **INSTALLATION**

Solenoid valve can be mounted in any position.

► **MATERIALS**

Body Anodized aluminum
Pinching device POM (reinforced acetal copolymer)
Internal components Stainless steel
Core tube Chemically nickel coated brass (Ni-P)

► **COIL**

Continuous duty ED 100%
Encapsulation material PA (Polyamide) fiberglass reinforced
Insulation class F (155°C)
Ambient temperature -10°C +60°C
Electric connection DIN 46340
Protection degree IP 40 (EN 60529) with female wire terminals 2,8x0,5 totally insulated
Voltages DC 12-24V (+10% -5%)
 (Other voltages on request).

| TUBINGS | | Tubing minimum wall thickness (mm) | Pinching strength (kg) | Series and type | | Power absorption (W) | Notes | Weight (kg) |
|-----------|-----------|------------------------------------|------------------------|-----------------|-------|----------------------|-------|-------------|
| I.D. (mm) | O.D. (mm) | | | Valve | Coil | | | |
| 0,76 | 1,65 | 0,4 | 0,180 | S104-07 | ZE30A | 4 | 1 | 0,050 |
| 1,02 | 2,16 | 0,5 | 0,220 | S104-08 | | | | |
| 1,57 | 3,18 | 0,7 | 0,280 | S104-09 | | | | |
| 1,98 | | 0,5 | 0,250 | S104-10 | | | | |

► **NOTE**

- If the soft tubings are different from the ones indicated, it's important that the tubing minimum wall thickness is the same as shown in the table.
- For the use of a soft tubing with outside diameter smaller than 2,2mm it is necessary to install the tubing guide sleeve (drawing K29501).
- In case the tubing is not placed in its seat, the solenoid valve could operate incorrectly.
- 1 - Model available on request only; ask for minimum quantity.

THE VALIDITY OF REPORTED DATA IS REFERRED TO THE DATE OF ISSUE. POSSIBLE UPDATES ARE AVAILABLE ON REQUEST

0705/1301