

Flow Switch UM3K-...V



- Soldered/welded connection
- Micro switch
- Low pressure loss
- Compact design
- Threaded connection
- Plug DIN 43650-A / ISO 4400

Characteristics

The devices function via the principle of a spring-supported paddle, and the magnetic triggering of a micro switch.

Technical data

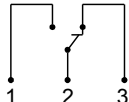
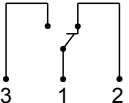
Switch	micro switch	
Nominal width	DN 15..80	
Process connection	soldered/welded nozzle (further process connections available on request)	
Switching range	10..268 l/min	for details see table "Ranges"
Q_{max.}	to 600 l/min	
Tolerance	±15 % of full scale value	
Pressure	PN 25 bar	
Medium temperature	-20..+110 °C	
Ambient temperature	-20..+70 °C	
Media	water (oils, gases and aggressive media available on request)	
Wiring	changeover no. 0.371  optionally changeover No. 0.282  optionally red or red / green diode in the DIN 43650-A plug	
Switching voltage	max. 250 V AC (gold contact max. 125 V AC / 30 V DC)	
Switching current	max. 5 A (round plug connector max. 4A) (gold contact max. 100 mA)	
Protection class	2 - safety insulation	
Ingress protection	IP 65	
Electrical connection	plug DIN 43650-A / ISO 4400, optionally for round plug connector M12x1, 4-pole	

Materials medium-contact	<i>Brass construction:</i> CW617N, CW614N nickelled, 1.4310, 1.4301, hard ferrite, NBR	<i>Stainless steel construction:</i> 1.4305, 1.4571, 1.4310, 1.4310, Hard ferrite PTFE coated, FKM
Non-medium-contact materials	ABS, PA, NBR	
Weight	0.3 kg	
Installation location	Standard: horizontal inwards flow; switching head not recommended underneath; other installation positions are possible; the installation position affects the switching point and range.	

Ranges

Details in the table correspond to horizontal inwards flow with decreasing flow rate

DN	Switching range l/min H ₂ O	Types	Q _{max.} recommended
DN 15	10.0 - 13.0	UM3K-015V.	20
DN 20	17.5 - 22.0		20
DN 25	18.0 - 22.5	UM3K-025V.	40
DN 32	44.0 - 55.5		40
DN 40	55.5 - 72.0		40
DN 50	75.0 - 90.0	UM3K-050V.	80
DN 65	151.0 - 186.0		80
DN 80	228.0 - 238.0		80
			80

Special ranges are available.

Dimensions

DN	Types	H	D	A	B
DN 15..20	UM3K-015V.	18.5	13	-	-
DN 25..40	UM3K-025V.	27.0	-	12	16
DN 50..80	UM3K-050V.	40.5	-	-	19

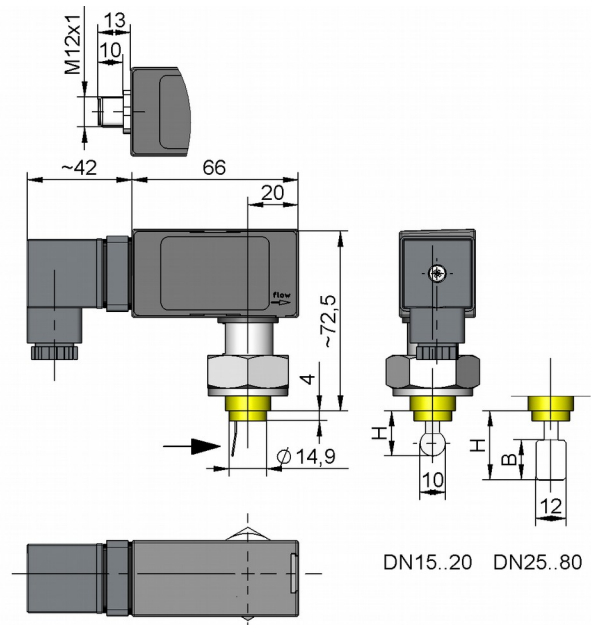

... professional Instruments "MADE IN GERMANY"

Handling and Operation

Note

- Include straight calming section of 5 x DN in inlet and outlet
- When tightening the union nut, the connection piece must be countered using an open-ended spanner (SW 19).
- If the media are dirty, install a filter (use magnetic filter for ferritic components).
- It must be ensured that the values given for voltage, current, and power are not exceeded.
- When switched on, a load must be connected in series.
- The electrical details apply to ohmic loads. Capacitive and inductive loads must be operated using a protective circuit.

Adjustment

To adjust, open the slider. Adjustment is made using the adjustment screw with a lengthways slot; this is located under the valve.

Turn clockwise for a lower switching point; turn anticlockwise for a higher switching point.

After adjustment, close the slider again.

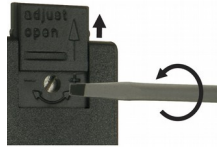

Example: The adjustment range 20 to 27 l/min corresponds to 7 l/min Adjustment option in 7 revolutions. Adjustment is therefore 1 l/min for each revolution.

Ordering code

UM3K - 1. 2. 3.

○=Option

1. Nominal width	
015	DN 15..20
025	DN 25..40
050	DN 50..80
2. Process connection	
V	soldered/welded nozzle
3. Connection material	
M	brass
K	stainless steel

Options

- Connection for round plug-in connector
- Signal lamp red or red/green in the plug DIN 43650-A
- Gold contact 125 V AC / 30 V DC, 100 mA
- Protective bellows
- Switching ranges for oil or gas
- Special values
- Adhesive PVC fitting

Ordering information

- Specify direction of flow, medium, and switching range.
- For oils, state viscosity, temperature and designation (e.g. ISO VG 68) (enquire about range).
- For gases, state pressure (relative or absolute), temperature and medium (e.g. air) (enquire about range).