

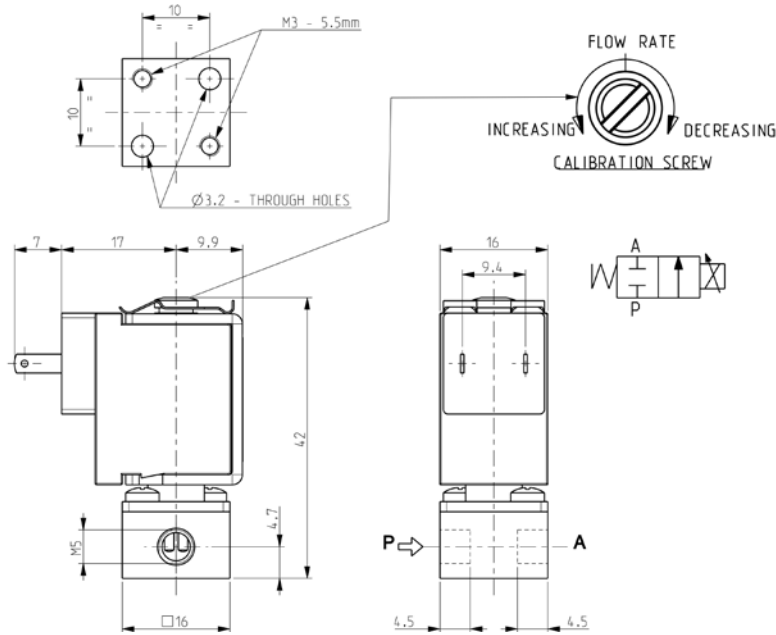

**MICRO SOLENOID VALVE**  
**2 ways - NC (Normally closed)**  
 Direct acting  
**M5**

<b>V164B90</b>
PROPORTIONAL - ADJUSTABLE
FLOW CONTROL



► **GENERAL FEATURES**

Direct acting micro solenoid valve. Minimum overall dimensions.  
 Suitable to shut off liquid and gaseous fluids (verify the compatibility of fluid with materials in contact).  
 The flow rate is proportional to the input electric signal.  
 The proportional response feature (flow rate/electric signal) can be calibrated by the customer so to match several applications. Overleaf the charts show the features of standard valves calibrated at the factory as example of the possible operating conditions.

► **CALIBRATION**

The flow calibration has to be carried out as if the valve was in operation:  
 - inlet fluid pressure at the selected constant value  
 - operating simulator at the outlet  
 - energizing the valve with the chosen electric signal.  
 Adjust the calibration screw till the desired flow is achieved.  
 De-energize the coil and check the valve tightness (1).  
 Rectify the calibration if necessary and check the flow rate again.  
 Once the valve is calibrated seal the calibration screw by using any suitable sealant.  
 (We recommend the use of 3M Scotch-Weld™ DP 190).  
**WARNING:** the calibration screw does not guarantee the tightness, Therefore, during the calibration there will be a weak leakage; don't calibrate the valve while using toxic fluids.

► **TECHNICAL FEATURES**

Maximum allowable pressure (PS) 16 bar  
 Fluid temperature -10°C +90°C  
 Max viscosity 3°E (22 cStokes or mm²/s)

► **MATERIALS IN CONTACT WITH FLUID**

Body Brass  
 Sealing NBR  
 Internal components Stainless steel  
 Seat Brass  
 Core tube Stainless steel

► **COIL**

Continuous duty ED100% (see note "A" overleaf)  
 Encapsulation material PA (Polyamide) fiberglass reinforced  
 Insulation class F (155°C)  
 Ambient temperature -10°C / +60°C  
 Electric connection DIN 46340  
 Protection degree IP 40 (EN 60529) with female wire terminals 2,8 x 0,5 totally insulated  
 Voltages DC 12 - 24V

Port size ISO-UNI 4534	Orifice size (mm)	Inlet differential pressure (bar)	Kv (m³/h)	Series et type		Power absorption			Sealings	Notes	Weight (kg)
				Valve	Coil	AC (VA)		DC (W)			
						Inrush	Holding				
M5	1,6	0,5 ÷ 5	0,04	V164B90	ZE30A	-	-	4	NBR	-	0,060
		0,2 ÷ 3						2,5			

► **NOTE**

- These micro-solenoid valves are not suitable for stagnating media subject to vaporization which deposit solid, calcareous, incrusting residues or similar.
- Seal: NBR = Nitrile-butylene elastomer
- Factory calibrated versions are available, ask for the relative data sheet
- Available with Z031 coil on request (Electric connections: DIN 46340 – micro plug connector; Protection degree: IP65)
- (1) The maximum sealing pressure at de-energized coil changes in relation with the calibration.

# V164B90

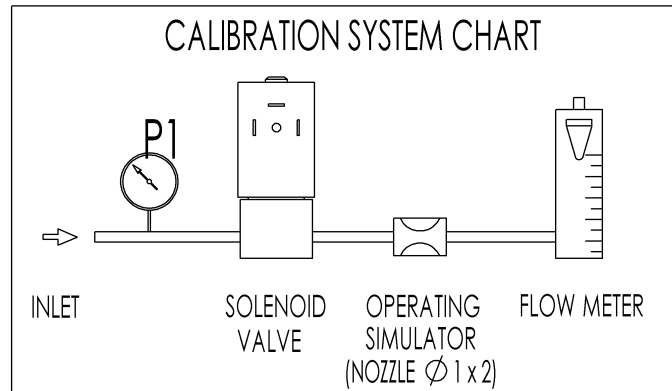

**V164B90 – ZE30C/ZE30A (orifice size=1.6mm)**  
 CHARACTERISTIC CURVE AT INLET PRESSURE =1bar (ZE30C) and 3 bar (ZE30A) (dehumidified and non-lubricated air)  
 NB: maximum sealing pressure at de-energized coil =3,5 bar for ZE30C and 5,5bar for ZE30A  
 Reference coil 24V DC  
 (See note "A")

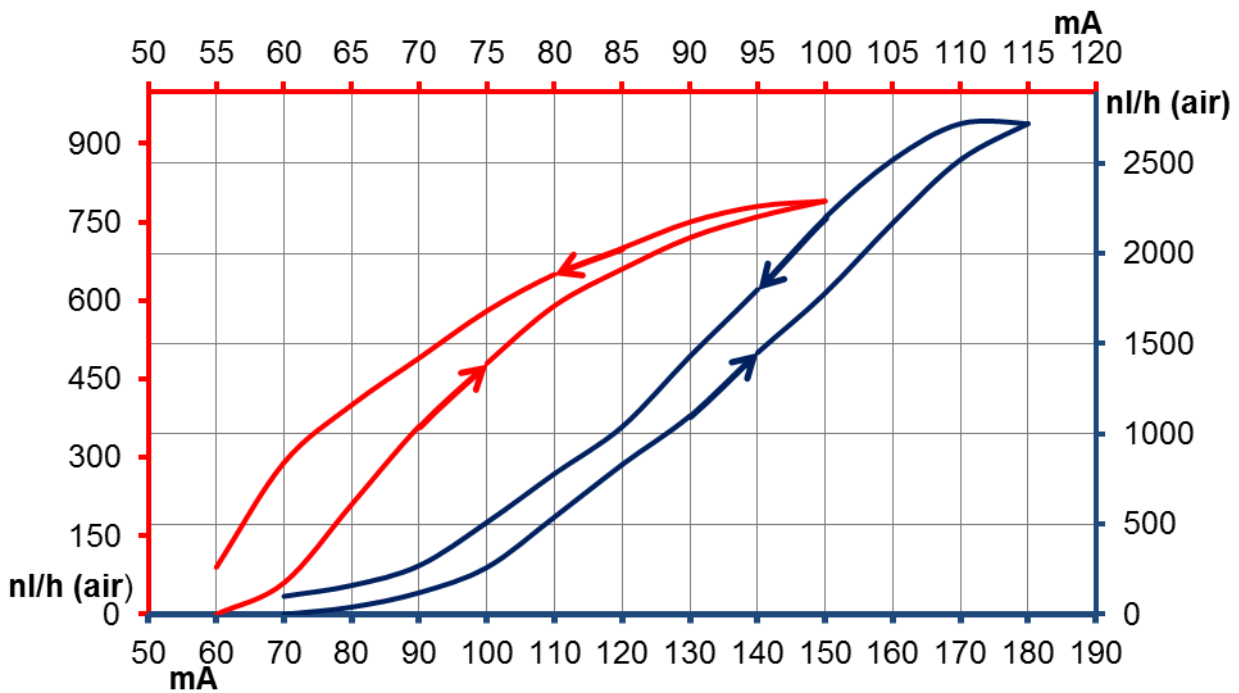

► **INSTALLATION**

Solenoid valve can be mounted in any position; vertical with coil upwards preferred.

► **NOTA "A"**

It is necessary to keep the current circulating in the coil constant, so as to maintain the solenoid valve in any pre-determined position. In case the solenoid valve is energized by voltage variation, it has to be considered that the resistance of winding increases because of the continued energizing and consequently the power decreases. Therefore, it is necessary to compensate such power decrease by increasing the voltage to re-establish the initial current value.